

Magnetic Drill Model CSU 32RL

Parts interchangeable with ECO-32T and ECO-32TAK
purchased from CS Unitec, Inc. prior to April 30, 2012

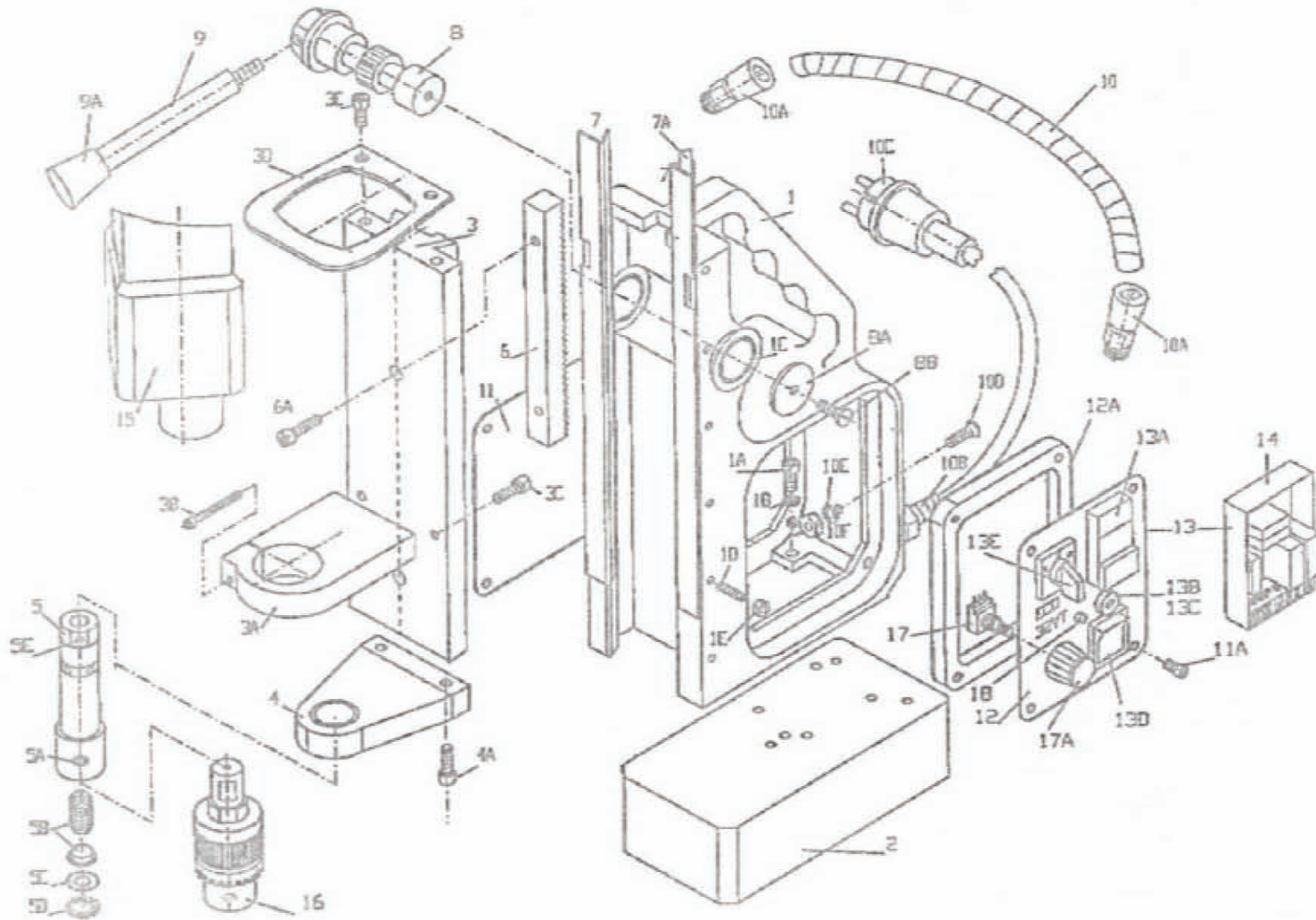

CS Unitec, Inc

22 Harbor Avenue, Norwalk, CT 06850

Telephone: 203-853-9522 • Toll Free: 800-700-5919 • Fax: 203-853-9921

Website: www.csunitec.com • E-Mail: info@csunitec.com

Magnetic Drill Model CSU 32RL

Parts interchangeable with ECO-32T and ECO-32TAK
purchased from CS Unitec, Inc. prior to April 30, 2012

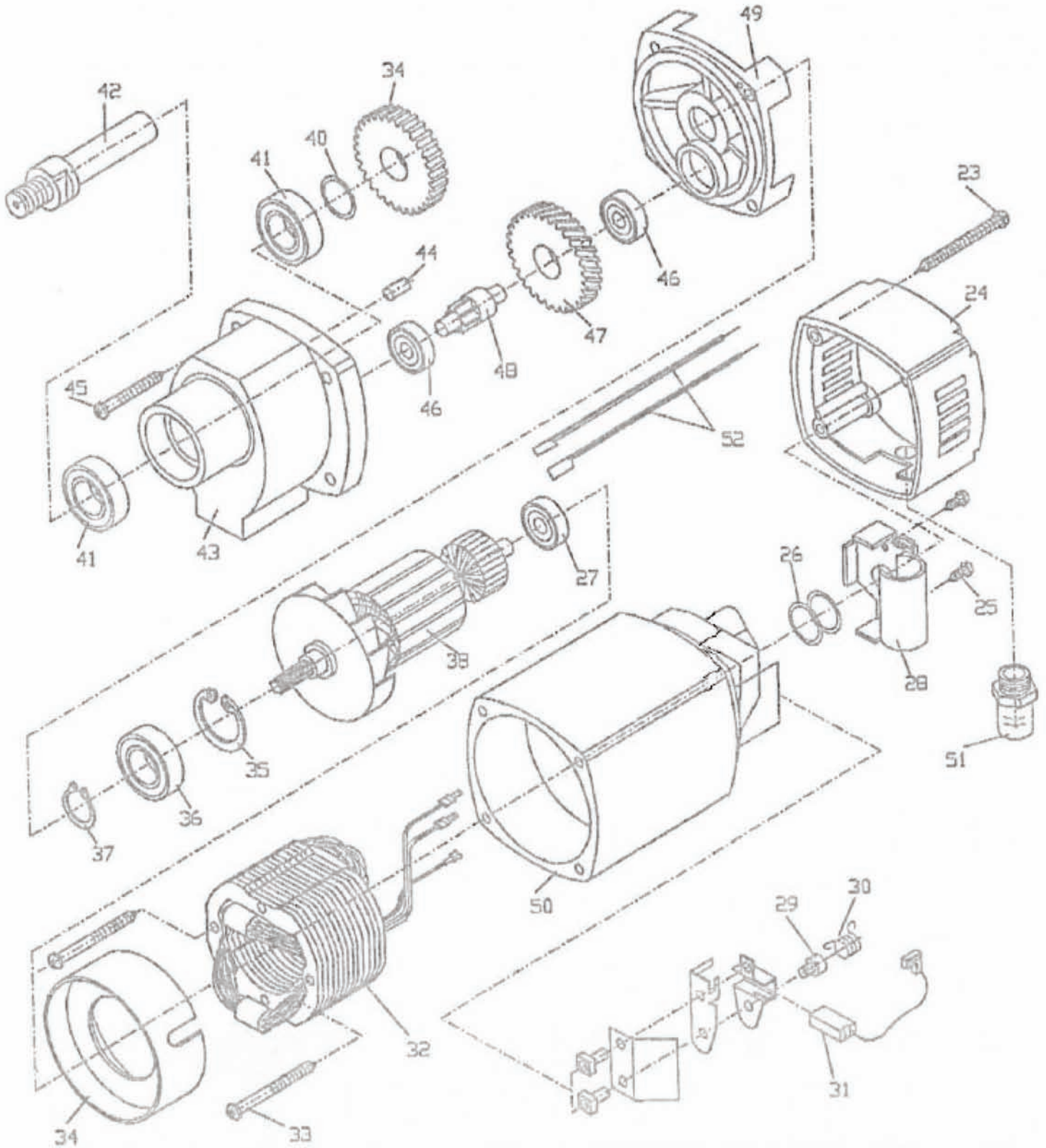

CS Unitec, Inc

22 Harbor Avenue, Norwalk, CT 06850

Telephone: 203-853-9522 • Toll Free: 800-700-5919 • Fax: 203-853-9921

Website: www.csunitec.com • E-Mail: info@csunitec.com

Not responsible for typographical errors.

<u>POS. NO.</u>	<u>ITEM NO.</u>	<u>DESCRIPTION</u>	
	020.0077	End Plate	
	020.0087	Brass Rail Set (Profile)	
	020.0098	Setting Set	
	020.0171	Front L/R Switch	
10a	020.0041	Cable Gland	
10b	020.0031	Cable Gland	
10c	020.0036	Power Cord	
10d	020.0182	Screw	
11a	032T.0003	Screw, Panel	
11b	020.0101	Screw	
12a	032T.0009	Spacer	
13a	020.0006	Switch, On/Off	
13b	020.0016	Fuse Holder	
13c	020.0019	Fuse	
13d	020.0011	Magnet Switch	
13e	032T.0051	Switch, Left/Right	
18a	032T.0062	LED Holder	Part of Pos. No. 17a
1a + 3e	020.0106	Socket Screw	
1b	020.0111	Washer	
1c	020.0096	Nut	
1d	020.0091	Screw	
20 + 21 + 22	KSP 200	Coolant Assembly Complete	
3a	032.0026	Motor Holder	
3b + 4a	020.0146	Socket Screw	
3c + 6a	020.0156	Screw for Springball	
3d	032.0041	Motor Fixing Plate (top)	
5a	020.0136	Screw See # 238-910	
5b + 5c	020.0121	Spring	
7 + 7a	020.0086	Brass Rail Set	
8a	020.0076	End Bush	
8b	020.0081	Screw	
9 + 9a	020.0066	Handle	
1	020.0056	Frame	
2	020.0051	Magnet	
3	032.0011	Slide	
4	020.0142	Steady Auto-Coolant	
5	020.0116	Arbor Spindle	Replaces 032T.0032
6	032.0016	Rack	
8	020.0061	Rack & Pinion	
10	032T.0046	Motor Cable	
11	032.0006	Rear Plate	
12	032T.0001	Front Plate	
14	032T.0007	Control Unit	
15	032T.0102	Motor Unit	

CS Unitec, Inc

22 Harbor Avenue, Norwalk, CT 06850

Telephone: 203-853-9522 • Toll Free: 800-700-5919 • Fax: 203-853-9921

Website: www.csunitec.com • E-Mail: info@csunitec.com

Not responsible for typographical errors.

POS. NO.	ITEM NO.	DESCRIPTION	
17	032T.0056	Speed Control	
18	032T.0061	LED Indicator	
23	80201284	Screw	Replaces 032.0106
24	032.0111	End Cover-REPLACES #032T.007	
25	032.0116	Adaptor Ring Cap Screw	
26	032.0121	Adapter Ring	
27	032.0126	Bearing	
28	032.0131	Condenser Holder	
29	032.0136	Screw	
30	032.0141	Spring	
31	032.0146	Brush	
32	032T.0117	Field, 110 Volt	
33	80201266	Screw	Replaces 032.0156
34	032.0161	Ring, air guiding	
35	032.0166	CirClip	
36	80410031	Bearing	Replaces 032.0171
37	032.0176	Circlip	
38	032T.0147	Armature, 110 Volt	
39	032.0186	Gear, Spindle	
40	032.0191	Washer fitting	
41	032.0196	Bearing	
42	032.0201	Spindle Drive Shaft	
43	032.0206	Gear Casing	
44	80200582	Notched Pin	Replaces 032.0211
45	032.0216	Screw	
46	80410011	Bearing	Replaces 032.0221
47	032.0226	Gear	
48	032.0231	Axle	
49	032.0236	Inner Gear Plate	
50	032.0241	Housing	

CS Unitec, Inc

22 Harbor Avenue, Norwalk, CT 06850

Telephone: 203-853-9522 • Toll Free: 800-700-5919 • Fax: 203-853-9921

Website: www.csunitec.com • E-Mail: info@csunitec.com