

PLEASE SPECIFY TOOL MODEL # WHEN ORDERING PARTS

<b>PARTS BREAKDOWN</b>	<b>Model #:</b> MAB 1300	<b>Bulletin #:</b> 03-2011
<b>PARTS LISTING</b>	<b>Description:</b> Portable Magnetic Drill	<b>Prepared By:</b> SCW
<b>WIRING DIAGRAM</b>	<b>Date:</b> 11/28/2011	

### MAB 1300 MOTOR BREAKDOWN

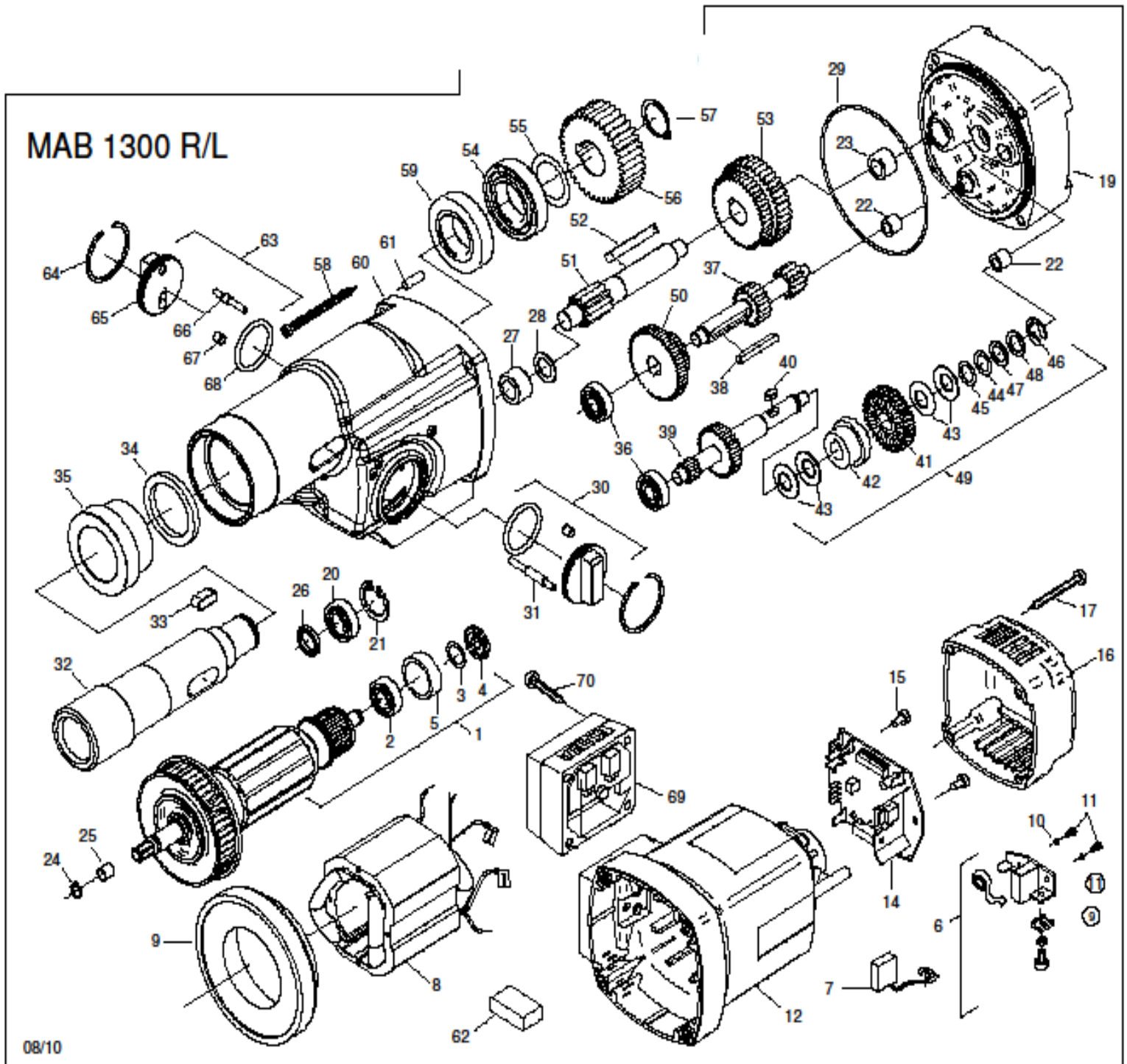

**PLEASE SPECIFY TOOL MODEL # WHEN ORDERING PARTS**

<b>PARTS BREAKDOWN</b>	Model #: MAB 1300	Bulletin #: 03-2011
<b>PARTS LISTING</b>	Description: Portable Magnetic Drill	Prepared By: SCW
<b>WIRING DIAGRAM</b>	Date: 11/28/2011	

### MAB 1300 MOTOR PARTS LIST

Pos. #	Part #	Description
1	5013921	Armature 220-240V
1A	5013931	Armature 110 V
2	5011301	Ball bearing 6000 2Z
3	5013941	Sealing ring 10 x 14 x 1
4	5013951	Ring magnet
5	5011561	Bearing cap
6	5011601	Carbon brush holder compl
7	5012531	Carbon brush 6,2 x 16
8	5014401	Field coil 220-240V
8A	5014402	Field coil 110V
9	5013971	Air conducting ring
10	5013981	Spring washer B4
11	5013991	Screw ZM4 x 12
12	5011631	Motor housing
14	5011541	PC board 220-240V
14A	5011551	PC board 110V
15	5010951	Screw HF3,9 x 9,5
16	5011531	Cap for motor housing
17	5010581	Screw 4,8 x 45
19	5014031	Shield plate
20	5014041	Ball bearing 6201 LUZ
21	5014441	Circlip ring 32/1,2
22	5010351	Needle bearing HK 0810
23	5014411	Needle bearing HK 1212
24	5014421	Circlip ring 12/1
25	5014081	Ring for bearing
26	5013601	Shaft seal KEIV 15x21x3
27	5011261	Needle bearing RNA 4900
28	5014091	Washer for needle bearing
29	5050091	Transmission seal
30	5014101	Gear change long

Pos. #	Part #	Description
31	5014111	Pin for gear position (1)
32	5014121	Spindle
33	5011161	Spring 6 x 6 x 20
34	5014431	Washer for ball bearing
35	5014141	Needle bearing NAXK40
36	5011011	Ball bearing 6000
37	5014151	Intermedium shaft 2
38	5014161	Spring 5 x 5 x 40
39	5014171	ntermedium shaft 1
40	5014181	Spring 5 x 5 x 10
41	5011651	Clutch wheel
42	5011351	Half of clutch
43	5011331	Cup spring 28/12,2 x 1
44	5012651	Washer 12 x 0,2
45	5011391	Washer 1
46	5011411	Circlip ring 9
47	5050201	Disc 12 x 0,5
48	5011381	Spacer 2
49	5014231	Clutch compl.
50	5014241	Gear wheel assembly 1
51	5014251	Intermedium shaft 3
52	5014261	Spring 6 x 6 x 50
53	5014271	Gear wheel assembly 2
54	5012331	Ball bearing 6000 2RS
55	5011181	Washer 25/35 x 0,1
56	5014281	Spindle wheel
57	5014291	Circlip ring 25/1,2
58	5014301	Screw HC5,5x80
59	5014311	Shaft seal 38x48x6
60	5014321	Gear box case
61	5011481	Pin 5x16

**PLEASE SPECIFY TOOL MODEL # WHEN ORDERING PARTS**

<b>PARTS BREAKDOWN</b>	<b>Model #:</b> MAB 1300	<b>Bulletin #:</b> 03-2011
<b>PARTS LISTING</b>	<b>Description:</b> Portable Magnetic Drill	<b>Prepared By:</b> SCW
<b>WIRING DIAGRAM</b>	<b>Date:</b> 11/22/2011	

**MAB 1300 MOTOR PARTS LIST - *continued***

Pos. #	Part #	Description
62	5014341	Pin 30x20x15
63	5014351	Gear change
64	5014551	Circlip ring SB42
65	5014371	Gear change
66	5014381	pin for gear position (2)
67	5014561	compression piece
68	5014601	O-Ring 36x1,5
69	5011981	Housing for potentiometer
70	5011971	Screw M6x45

PLEASE SPECIFY TOOL MODEL # WHEN ORDERING PARTS

<b>PARTS BREAKDOWN</b>	<b>Model #:</b> MAB 1300	<b>Bulletin #:</b> 03-2011
<b>PARTS LISTING</b>	<b>Description:</b> Portable Magnetic Drill	<b>Prepared By:</b> SCW
<b>WIRING DIAGRAM</b>	<b>Date:</b> 11/22/2011	

### MAB 150 STAND BREAKDOWN

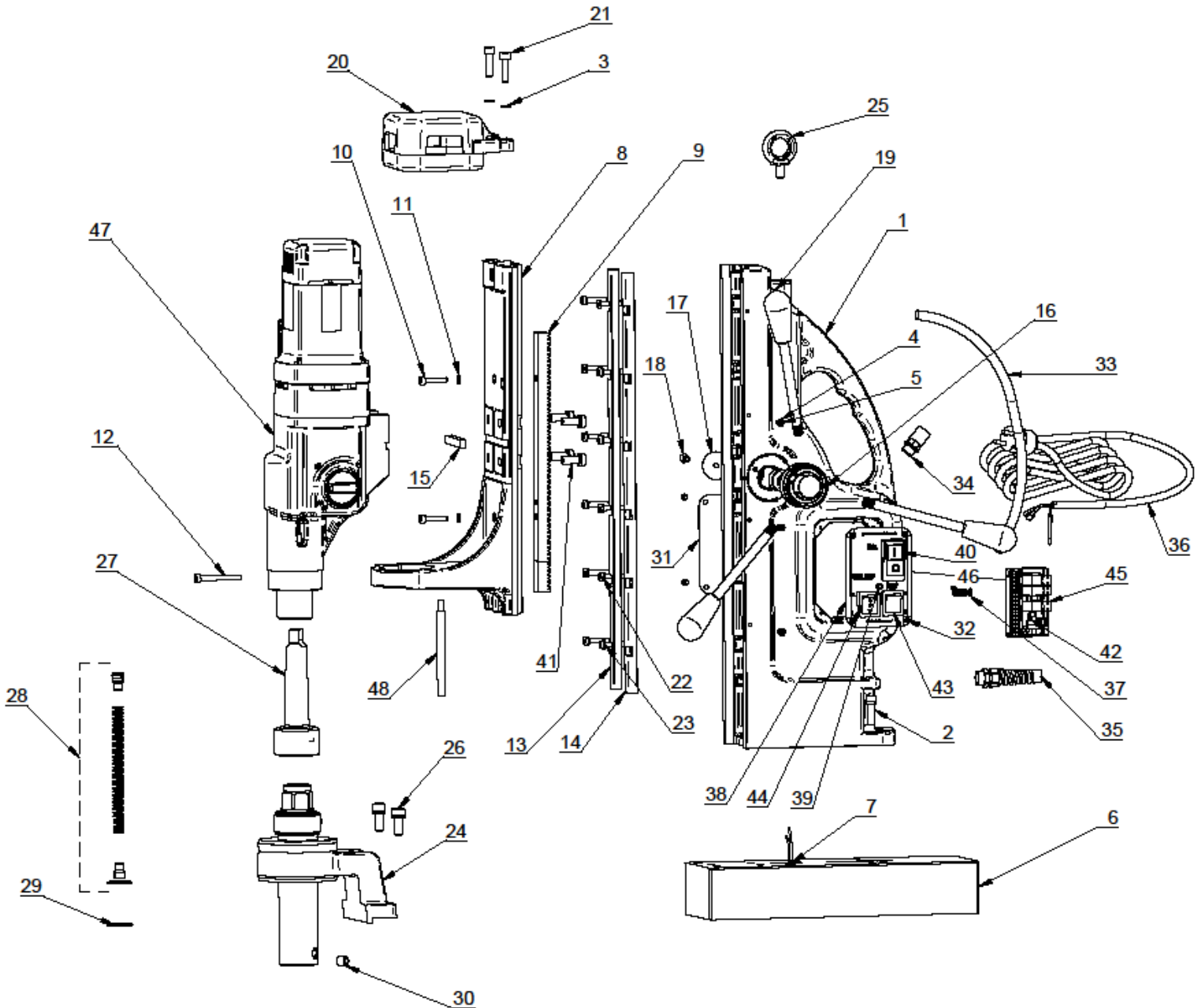

**PLEASE SPECIFY TOOL MODEL # WHEN ORDERING PARTS**

<b>PARTS BREAKDOWN</b>	<b>Model #:</b> MAB 1300	<b>Bulletin #:</b> 03-2011
<b>PARTS LISTING</b>	<b>Description:</b> Portable Magnetic Drill	<b>Prepared By:</b> SCW
<b>WIRING DIAGRAM</b>	<b>Date:</b> 11/28/2011	

### MAB 150 STAND PARTS LIST

Pos. #	Part #	Description
1	6030011	Housing
2	6050101	Screw M8 x 30
3	6010571	Spring washer 8,3
4	6010031	Nut M5
5	6010041	Set screw M5 x 16 for slide
6	6030071	Magnet (electric) with indicator M8
7	6010061	Indicator for magnet with cable
8	6030021	Slide with gearbox holder
9	6030031	Rack
10	6050231	Screw M6x30
11	6010571	Spring washer 8,3
12	6050211	Screw M6 x 55
13	6030041	Guide rail left
14	6030051	Guid rail right
15	6030061	Spring
16	ZPA 403	Power assistant
17	6010221	Washer for rack
18	6010231	Screw for gear wheel M6 x 16
19	6010542	Handle rod with knob
20	6030081	Cover for motor black
21	6050241	Screw M8 x 35
22	6050141	Screw M6 x 25
23	6050151	Washer 6,4 x 11 x 1,6
24	6030091	Holder industrial arbor
25	7011711	Screw SC M10 WLL023E 3BAA C15
26	7011721	Screw DIN 912 M10 x 30
27	6030101	Arbor CM 4
28	6010761	Spring with washer
29	6010771	Circlip ring
30	6010781	Screw M12 x 12 for core drill fixing
31	7011731	Side plate

Pos. #	Part #	Description
32	7010081	Screw for side plate M4x6
33	7010001	Cable protection
34	7010021	Cable gland PG 9
35	7010031	Mains cable gland PG 11
36	7010042	Connection cable 220 - 240 V with plug
36 A	7010052	Connection cable 220-240 V with GB- plug
36 B	7010242	Connection cable 110 V (plug on demand)
37	7010061	Earthing compl.
38	7011472	Switch plate front side for indicator
39	7010101	LED-display for indicator red/ green
40	7010111	Actuator 230 V
40 A	7010931	Actuator 110 V
41	7011721	Screw DIN 912 M 10 x 30
42	7010131	Fuse 2A, 5x20, 250 V F DIN 41 661
43	7010142	Magnet switch IP 65
44	7010481	Rocker switch right/left
45	6012151	PC board with 3 relays 230 V
45 A	6012301	PC board with 3 relays 110V
46	7011751	Switch plate compl. with PC board 230 V
46 A	7011761	Switch plate compl. with PC board 110 V
47	5001302	Motor MAB 1300 compl. 230V right/left
47 A	5001312	Motor MAB 1300 compl. 100V right/left
48	7011771	Stop pin 125 mm

PLEASE SPECIFY TOOL MODEL # WHEN ORDERING PARTS

<b>PARTS BREAKDOWN</b>	<b>Model #:</b> MAB 1300	<b>Bulletin #:</b> 03-2011
<b>PARTS LISTING</b>	<b>Description:</b> Portable Magnetic Drill	<b>Prepared By:</b> SCW
<b>WIRING DIAGRAM</b>	<b>Date:</b> 11/22/2011	

### MAB 1300 WIRING DIAGRAM

