

PLEASE SPECIFY TOOL MODEL # WHEN ORDERING PARTS

<b>PARTS BREAKDOWN</b>	<b>Model #:</b> MAB 485	<b>Bulletin #:</b> 06-2011
<b>PARTS LISTING</b>	<b>Description:</b> Portable Magnetic Drill	<b>Prepared By:</b> SCW
<b>WIRING DIAGRAM</b>	<b>Date:</b> 11/29/2011	

### MAB 485 MOTOR BREAKDOWN

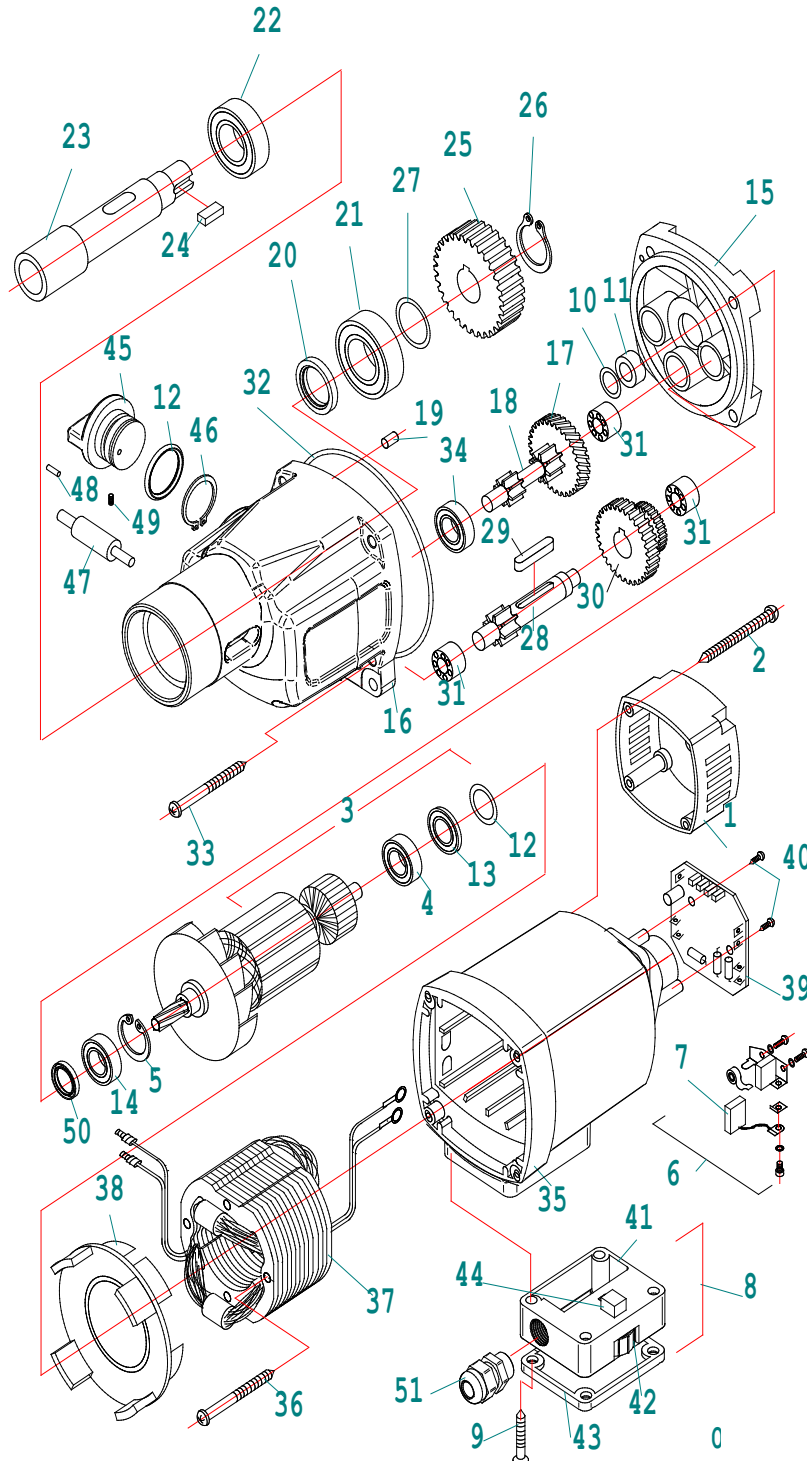

**PLEASE SPECIFY TOOL MODEL # WHEN ORDERING PARTS**

<b>PARTS BREAKDOWN</b>	Model #: MAB 485	Bulletin #: 06-2011
<b>PARTS LISTING</b>	Description: Portable Magnetic Drill	Prepared By: SCW
<b>WIRING DIAGRAM</b>	Date: 11/29/2011	

### MAB 485 MOTOR PARTS LIST

Pos. #	Part #	Description
1	5010691	Cap for motor housing
2	5010581	Screw 4,8 x 45
3	5013391	Armature 230V
3 A	5013401	Armature 110V
4	5010061	Ball bearing 608 2Z
5	5010271	Circlip ring 28/1,2
6	5010561	Carbon brush holder
7	5010571	Carbon brush 6,3x10x18
8	5012512	Housing for potentiometer (100kOhm)
8 A	5012511	Housing for potentiometer compl.
9	5012491	Screw M5 x 40
10	5012991	Circlip ring SW 10
11	5013411	Sealing sleeve
12	5010591	Washer 22 x 2,5
13	5010781	Ring magnet
14	5012501	Ball bearing 6001 2RS
15	5013421	Shield plate
16	5013431	Gearbox housing
17	5013441	Intermedium gear wheel 34 teeth
18	5013451	Shaft with 2 pinions
19	5010291	Pin 4 x 12
20	5013461	Shaft seal 20 x 35 x 7
21	5010611	Ball bearing 6203 2RS
22	5011191	Ball bearing 6005 2RS
23	5013471	Spindle
24	5010751	Spring A5 x 5 x 12
25	5010621	Spindle wheel 45 teeth
26	5010721	Circlip ring 15/1
27	5010531	Circlip ring 15/22 x 0,2
28	5010411	Shaft for gear wheel 13 teeth
29	5010501	Spring A5 x 5 x 28

Pos. #	Part #	Description
30	5010631	Shaft for gear wheel 34/40 Z
31	5010351	Needle bearing HK 0810
32	5013481	O-Ring 85 x 1,78
33	5010231	Screw 4,8 x 50
34	5010071	Ball bearing 608
35	5010701	Motor housing compl.
36	5010031	Screw 3,9 x 60
37	5013491	Field coil 220-240V
37 A	5013501	Field coil 110V
38	5010641	Air conducting ring
39	5010841	PC board 220V
39 A	5010851	PC board 110V
40	5010791	Screws - 2 pcs.
41	5015031	Housing for potentiometer
42	5010861	Adjustment wheel blue for speed control 2V
43	5010891	Cover for housing for potentiometer
44	5010871	Potentiometer for speed control 250kOhm
45	5013551	Gear change
46	5013561	Circlip ring 26/1,2
47	5013571	Bolt
48	5013581	Pin 3m 6 x 10
49	5013591	Locking bolt
50	5013601	Shaft seal KEIV 15 x 21 x 3
51	6012131	Cable gland PG 9



**PLEASE SPECIFY TOOL MODEL # WHEN ORDERING PARTS**

<b>PARTS BREAKDOWN</b>	Model #: MAB 485	Bulletin #: 06-2011
<b>PARTS LISTING</b>	Description: Portable Magnetic Drill	Prepared By: SCW
<b>WIRING DIAGRAM</b>	Date: 11/29/2011	

### MAB 485 STAND PARTS LIST

Pos. #	Part #	Description
1	6012091	Housing 3 holes
2	6012231	Guide rail right for 4 screws
3	6010021	Spring washer 6,3
4	6010011	Screw M6 x 16
5	6010054	Magnet (electric) for indicator
6	6012101	Slide
7	6010111	Screw M6 x 25
8	6010081	Rack
9	6010091	Screw M6 x 20 DIN 912
10	6010211	Shaft for gear wheel
11	6010221	Washer for gear wheel
12	6010231	Screw M6 x 16 for gear wheel
13	6010242	Handle rod with knob
14	6012111	Coolant reservoir
15	6012121	Sphere for coolant reservoir
16	6010031	Nut M5
17	6010041	Screw M5x16 for slide
18	6012241	Guide rail (1 set right/left) to be glued
19	6012131	Cable gland
20	7010061	Earthing compl.
21	6012141	Quick coupling
22	ZSS 200S	Coolant tube
23	7010031	Mains cable gland PG 11
24	7010042	Connection cable 220-240V with plug
24 A	7010052	Connection cable 220-240V with GB-plug
24 B	7010051	Connection cable 110V (plug on demand)

Pos. #	Part #	Description
25	6012151	PC board with 3 relais 230V
25 A	6012161	PC board with 3 relais 110V
26	7010131	Fuse 2A, 5x20
27	6012171	Indicator with cable
28	7010101	LED-display for indicator red/green
29	7010081	Screw M4 x 6
30	7011041	Switch plate front side
31	7010142	Magnet switch IP65
32	7010802	Actuator 220V
32 A	7010931	Actuator 110V
33	7010481	Rocker switch right/left
34	6012181	Spring for motor cable
35	6012191	Motor cable
36	ZSS 200	Keyless ZSS 200
37	5004851	Motor compl. 230V
37 A	5004861	Motor compl. 110V
38	6010461	Screw M6 x 30
39	7011051	Side plate
40	7011062	"Switch plate compl. with PC board 3 relais 230V"
40 A	7011072	"Switch plate compl. with PC board 3 relais 110V"
39	7011051	Side plate
40	7011062	"Switch plate compl. with PC board 3 relais 230V"
40 A	7011072	"Switch plate compl. with PC board 3 relais 110V"

PLEASE SPECIFY TOOL MODEL # WHEN ORDERING PARTS

<b>PARTS BREAKDOWN</b>	<b>Model #:</b> MAB 485	<b>Bulletin #:</b> 06-2011
<b>PARTS LISTING</b>	<b>Description:</b> Portable Magnetic Drill	<b>Prepared By:</b> SCW
<b>WIRING DIAGRAM</b>	<b>Date:</b> 11/29/2011	

## MAB 485 WIRING DIAGRAM

