

# Pneumatic Drill

**2 2502 0010 / 2 2502 0030**

**2 2506 0010 / 2 2506 0030**

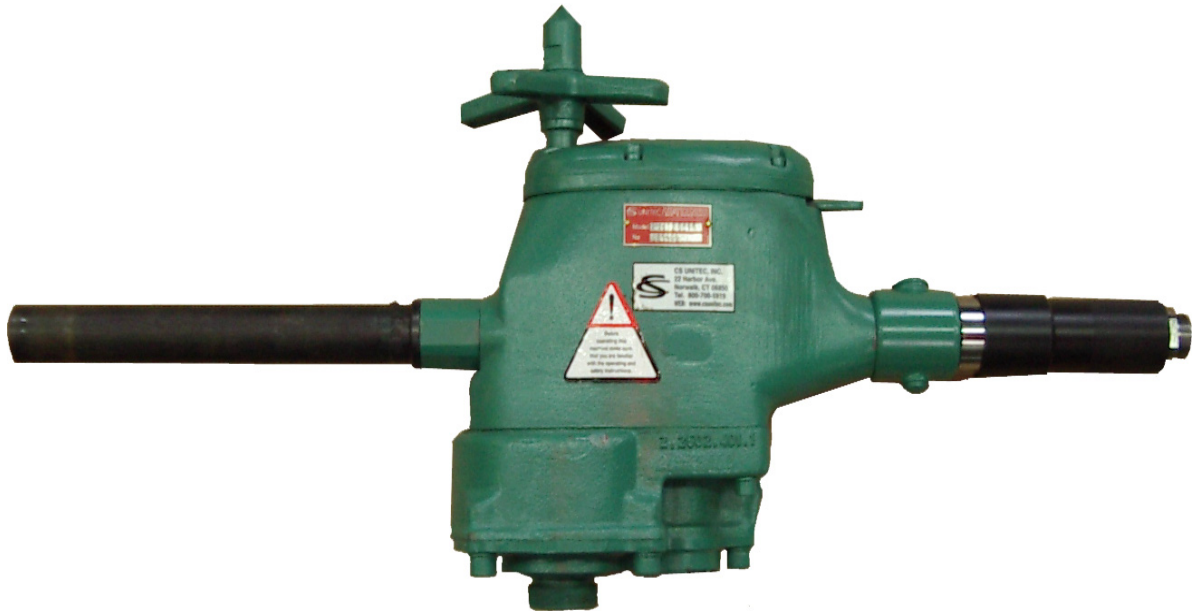

<b>Technical Specification</b>				
<b>Model with Lever Throttle</b>		<b>2 2502 0010</b>	<b>2 2506 0010</b>	
<b>Model with Twist Throttle with Self-resetting</b>		<b>2 2502 0030</b>	<b>2 2506 0030</b>	
Operating pressure (Flow pressure)	p	6	6	bar
Tool Holder – Morse Taper		MT 4	MT 3	
Drilling capacity in steel	dia.	50	32	mm
Reaming up to	dia.	32	26	mm
Speed (under load)	n	80	220	rpm
Air consumption		2	2	m <sup>3</sup> /min.
Air connection		R 3/4"	R 3/4"	male
ID of hose	dia.	15	15	mm
Power	P	1.85	1.85	kW
Weight, approx.		17.2	14.7	kg

## **- Operating Instructions**

Explain how to handle the machine and how to change drilling tools.

## **- Maintenance and Assembly Instructions**

This section contains the fundamentals of pneumatic tools, technical specifications, maintenance instructions, wear, disassembly and reassembly procedures.

## **- Spare Parts Documentation**

Consisting of parts lists, sectional drawings and/or exploded views.

## **- Supplement**

Information sheet „MAINTENANCE OF PNEUMATIC TOOLS“

Information on oiler adjustment.

# Operating Instructions

## General

Performance and output power of this machine are designed for a drilling capacity in steel up to 50 (32) mm diameter. At this free-hand drilling is not possible (**DANGER OF INJURY**). Therefore, always center the machine and secure it against rotation. **NEVER HOLD THE MACHINE ONLY BY HAND DURING DRILLING.**

## Drilling / Reaming (see figures 1 to 3)

- Check the oil level. If necessary, add oil to fill up the oiler.
- Attach desired tool to the machine (Morse taper 4 or 3).
- Screw the feed spindle as far as possible (capstan handle).
- Center and fix the machine on a suitable support.
- Secure motor part with oiler and valve against rotation (**do not hold it by hand**).
- Connect air hose. (In order to remove contaminants, blow out the air hose before connecting).
- Open the valve and begin the drilling or reaming. (Speed can be regulated by opening the valve more or less).
- Produce uniform feed by screwing out the spindle. (A capstan handle is available).
- Take care for sufficient cooling of tools and workpieces (by appropriate coolants).

## After finishing the operation

- Shut the valve.
- Turn off compressed air and disconnect the air hose.
- Take the machine out of device.
- Loosen the drills and reamers and pull them out of morse taper.
- Clean the arbor hole.
- Check oiler.



## Safety Precautions

- Wear safety glasses (**Danger of injury by means of metal chips**)
- Wear safety gloves (**Danger of injury by butting oneself on sharp-edged workpieces**).
- Wear protective clothing.
- Ensure that you maintain a good footing and proper balance at all times.
- Never work under the influence of alcohol, drugs or stronger medication.
- After use, shut valve immediately.
- Disconnect machine from air line (**avoidance of unintentionally turning of the machine**).
- Follow the general current and appropriate **ACCIDENT PREVENTION AND SAFETY PROCEDURES**.

Figure 1

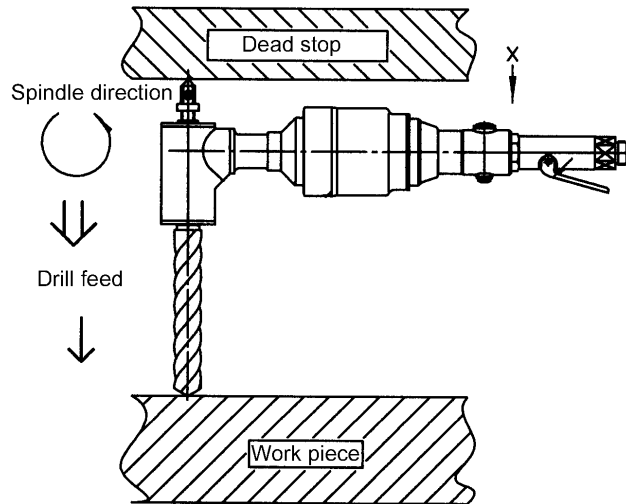

Figure 2

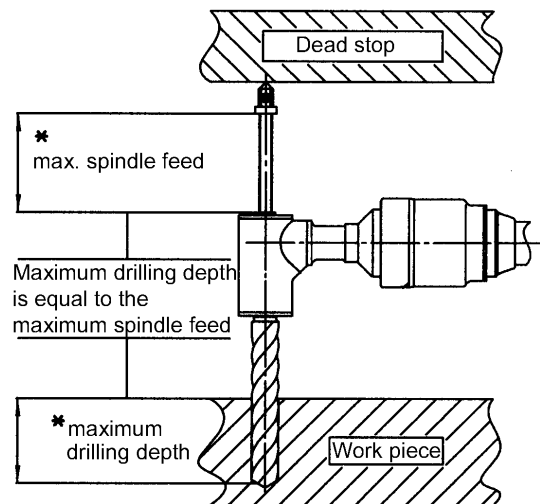
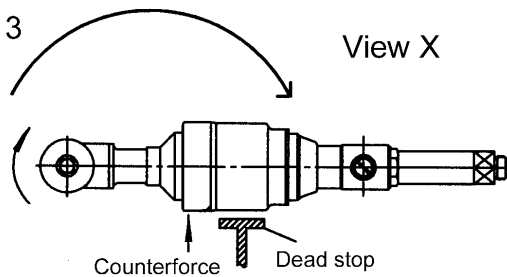

Figure 3



**Example:**

**Centring and securing against rotation**

## Maintenance and Assembly Instructions

Our machines are designed for an operating pressure of 4-6 bar (65-90 psi)

**Service life and performance** of the machine are decisively determined by:

- a) the air purity
- b) the lubrication conditions and maintenance

a) Blow the air hose clear before connecting it to the machine.

Install dirt and water separator upstream of the machine, if it is not possible to prevent the formation of rust and water condensation in the air distribution lines.

b) Only proper maintenance can ensure constant performance, reduction in wear and thus, a decrease in operating costs and an increase in service life.

It is recommended to check always contents of the built-in oiler which is located between machine and valve. Regularly check and clean the air inlet screen.

Use always acid- and resin-free SAE 5W – SAE 10W oil. Thick flowing oil will clog the vanes and affect the start-up and performance of the machine. We therefore highly recommend to install a service unit and line oiler upstream of the machine.

In winter, or if the compressed air is very moist, and antifreeze lubricant, e.g. „**BP-Energol AX 10**“, „**Kilfrost**“ or „**Kompranol N74**“ should be used.

Observe the comments in the information sheet

### „Maintenance of Pneumatic Tools“

The lubricated and sealed ball bearings may not be flushed.

Replace wear parts – in particular the vanes – when necessary. **Vanes are considered worn if their width is less than 17 mm.**

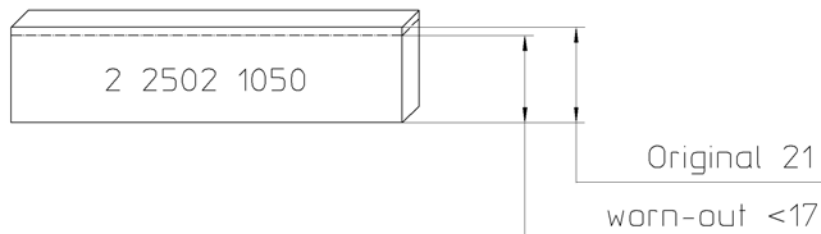

After ending a working task, flush the machine with as thin oil, or protect some other way against corrosion.

## **Disassembly and Reassembly:**

Disassembly and Reassembly should only be performed with assistance of the sectional drawing.

### **Motor ( 2 2502 )**

Remove feed spindle (33) and Fillister-head screws (80), detach housing cover (2), bend up the tab washer (61), unscrew the screw (60) and remove spacer (45) and the feather keys (66). Unscrew the fillister-head screws (79) and remove intermediate cover (3). Watch out for the Belleville springs (43), sealing (44) and shim (42). By carefully tapping on a wooden block, it is now possible to remove end plate (9) with grooved ball bearing (10) and spacer (57) and the vanes (7) could be checked. For the other motor components, the gearbox must now be removed as well.

### **Gearbox ( 2 2502 )**

Unscrew cap nut (30), remove cover lid (23) and fillister-head screws (55) and detach snap ring (68). Insert a round plate (dia. 20 mm) into the feed sleeve (31) and use the feed spindle (33), to carefully push off the bearing cover (24) and drilling sleeve (26) (do not cant them). Watch out for axial ball bearing (28) and intermediate ring (29). Remove the fillister-head screws (62) and (63) and take off gearbox cover (4) from motor housing (1). Press out gearbox and motor components. Watch out for feather key (69) and cotter (77).

### **Motor ( 2 2506 )**

Screw out feed sleeve (39) and the screws (118), detach housing cover (2) and loosen screw (100). Remove screws (117), detach intermediate cover (3). Watch out for the Belleville springs (109), sealing (108) und shim (121). By carefully tapping on a wooden block, it is now possible to remove end plate (9), grooved ball bearing (10) and spacer (99) and the vanes (7) could be checked. For the other motor components, the gearbox must now be removed as well.

### **Gearbox ( 2 2506 )**

Remove cap nut (36), screw out cover lid (25), loosen screws (116) and detach snap ring (79) Insert a round plate (dia 20 mm) into feed sleeve (37) and use the feed spindle (39), to carefully push off the gearbox cover (4) and the drilling sleeve (31) (do not cant them). Watch out for axial ball bearing (35), fitting plate (34,1 / 34,2) and steel roll (15). Press out bgearbox and motor components.

### **Oiler:**

The oiler adjustment screw (49) should be readjusted only if the oil throughput rate no longer meets the requirements. For adding oil just remove the screw plug (51). For adjusting the oiler under operating pressure turn the adjusting screw (49) counter-clockwise to open it until air bubbles slightly drift upwards through the oil.

## Reassembly:

The reassembly is essentially carried out in the reverse sequence. Ensure proper distance for the motor. The end clearance between rotor (6) and each of the end plates (9 and 11) should be approx. 0.04 mm. The chamfers in the spacers item 57 (98) and item 58 (99) should point to the centre of the rotor.

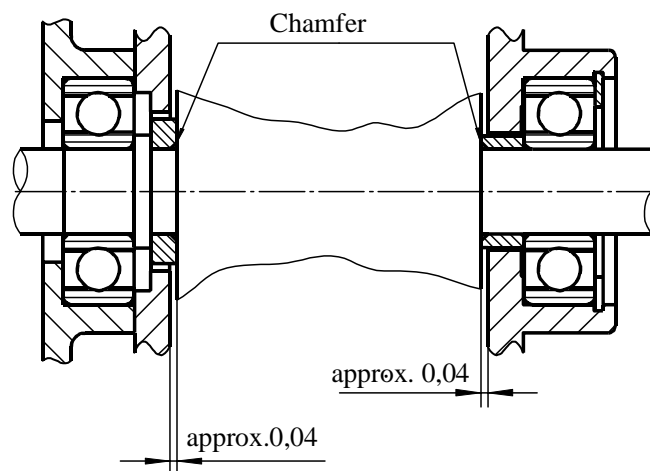

Remove any oil and resin residue from the rotor slots. The new vanes (item 7) should fit easily into the slots.

Use low viscosity grease (e.g. Calyptol D 6024) for the gearbox.

After completion of reassembly make functional gauging by checking free speed and air consumption as specified in „TECHNICAL SPECIFICATIONS“.

**Use only original spare parts for repairs!**