

Pneumatic Geared Motor Type 3 1638 0010

CS UNITEC, INC. • 22 HARBOR AVE., NORWALK, CT 06850 • PHONE: 203-853-9522 • TOLL-FREE: 800-700-5919 • EMAIL: INFO@CSUNITEC.COM

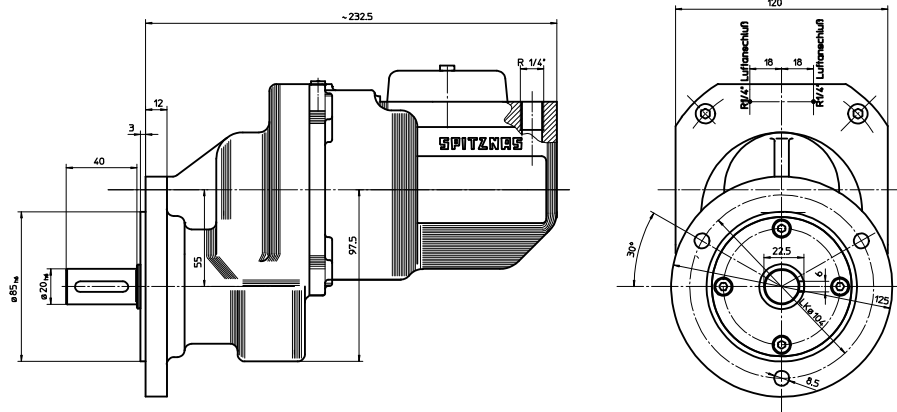

Illustration can differ from the original

Operation and Maintenance Instruction



Technical Specification

Operation Instructions

Basic information on pneumatic machines, maintenance hints, wear and tear, as well as disassembly and re-assembly procedure.

Spare Part Documentation

Parts lists and sectional drawings, resp. exploded views

Installation Declaration

TECHNICAL SPECIFICATION

| | | |
|------------------------------------|--------|-------------------------|
| Operating pressure (flow pressure) | | 6 bar (90 PSI) |
| Nominal output | p | 0.55 kW |
| Output speed (under load) | n bel | 110 1/min |
| Output speed (free speed) | n leer | 220 1/min |
| Air consumption at P Nenn | V | 0.9 m ³ /min |
| Weight approx. | | 9.5 kg |
| Output torque | M tA | 48.7 Nm |
| Air connection | 2 x | R ¼" |
| ID of hose | min. | Ø 9 mm |
| Gearbox ratio | i | 30.966 |

OPERATION INSTRUCTIONS

Maintenance and Assembly Instructions

Service life and performance of the motor are decisively determined by:

a) The air purity

Blow the air hose clear before connecting it to the motor. Install dirt and water separator upstream of the motor, if it is not possible to prevent the formation of rust and water condensation in the air distribution lines.

b) The lubrication conditions and maintenance

see „Maintenance of pneumatic tools“

Replace wear parts – in particular the vanes – in due time. Vanes are considered to be worn **when the width is less than 14 mm.**

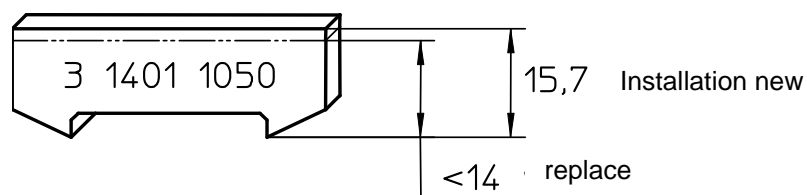

After using, flush the motor with a thin fluid oil or provide a comparable corrosion protection.

MAINTENANCE OF PNEUMATIC TOOLS

Only proper maintenance can ensure constant performance, reduction in wear and thus, a decrease in operating costs and an increase in service life.

Our pneumatic tools are equipped for an operating pressure of 6 bar. A regulator setting for an operating pressure of 4 bar is possible as well as expedient for grinding machines with a built-in regulator, so as to take full advantage of the speed prescribed for the corresponding grinding wheels.

Pneumatic tools should not run empty, because this results in heat and higher wear. The compressed air should be clean and dry. This is guaranteed by a proper pneumatic system. Blow through the pneumatic hose before connecting it. For the economical use of pneumatic tools, the prescribed air quantities are necessary, i.e., the line, armatures and hoses must have the required cross sections so that the flow pressure remains constant. Proper lubrication is a must; for this reason, our pneumatic tools usually have built-in oilers, which are located between the inlet valve and the motor, and which function in any position. In smaller and lighter hand tools, these oilers must often be left out, because the machines would then be too heavy and not easy to manage. In such cases, lubrication must be carried out by service units or by manual hose oilers. We recommend service units for permanently installed workplaces

(see accessories list). However, where longer hose lines are necessary, line oilers built into the hose lines are more effective. The distance between the tool and oiler should not be more than 5 m.

Most of pneumatic tools have located at the connection a lined-up screen, which is to be regularly checked and cleaned.

After ending a working task, the machines are to be flushed with a thin oil, or protected some other way against corrosion.

Visible grease nipples are provided for regular lubrication of the gears with a grease gun. Note the following for grease lubrication: Every 60 hours of operation check striking mechanism, friction bearings and antifriction bearings; if necessary, grease them. Every 300 hours of operation grease the gears and antifriction bearings anew. In the case of impact wrenches, use a grease gun to grease the anvil guide before beginning daily work or every 6 to 8 hours. All inner parts must be lubricated before storing for longer periods of time in order to prevent rusting. It is recommend to check the vanes and bearings at regular intervals. Store pneumatic tools in dry rooms only.

Lubricating oils to be used:
Generally SAE 5 W to SAE 10

For gearless impact wrenches and small grinders, only SAE 5 W

For damp compressed air, oils are to be used that take up water (without losing the lubricating effect) and that contain anticorrosive additives. At lower temperatures (especially for work outside) it may be necessary to use an antifreeze lubricant (e.g., Kilfrost, BP Energel AX 10, Kompranol N 74).

For saw-chain lubrication on chain saws:

Machine oil **with adhesive additive**, viscosity c ST 49-55' (6.5-7,5 E) / 50° C

Greases (free of resins and acids)

Multi-purpose greases for antifriction and friction bearings and gears

Special greases for high-speed miter gears

Designation in accordance with DIN 51502
Consistency class (DIN 51818)
Saponification type
Dripping point
Worked penetration
Temperature range

KL 2 K
2
lithium
185° C
265 to 295
-25° C to 125° C

G 00 h
00
sodium
145° C
400 to 410
-25° C to + 100° C



MAINTENANCE OF PNEUMATIC TOOLS

Only proper maintenance can ensure constant performance, reduction in wear and thus, a decrease in operating costs and an increase in service life.

Our pneumatic tools are equipped for an operating pressure of 6 bar. A regulator setting for an operating pressure of 4 bar is possible as well as expedient for grinding machines with a built-in regulator, so as to take full advantage of the speed prescribed for the corresponding grinding wheels.

Pneumatic tools should not run empty, because this results in heat and higher wear. The compressed air should be clean and dry. This is guaranteed by a proper pneumatic system. Blow through the pneumatic hose before connecting it. For the economical use of pneumatic tools, the prescribed air quantities are necessary, i.e., the line, armatures and hoses must have the required cross sections so that the flow pressure remains constant. Proper lubrication is a must; for this reason, our pneumatic tools usually have built-in oilers, which are located between the inlet valve and the motor, and which function in any position. In smaller and lighter hand tools, these oilers must often be left out, because the machines would then be too heavy and not easy to manage. In such cases, lubrication must be carried out by service units or by manual hose oilers. We recommend service units for permanently installed workplaces

(see accessories list). However, where longer hose lines are necessary, line oilers built into the hose lines are more effective. The distance between the tool and oiler should not be more than 5 m.

Most of pneumatic tools have located at the connection a lined-up screen, which is to be regularly checked and cleaned.

After ending a working task, the machines are to be flushed with a thin oil, or protected some other way against corrosion.

Visible grease nipples are provided for regular lubrication of the gears with a grease gun. Note the following for grease lubrication: Every 60 hours of operation check striking mechanism, friction bearings and antifriction bearings; if necessary, grease them. Every 300 hours of operation grease the gears and antifriction bearings anew. In the case of impact wrenches, use a grease gun to grease the anvil guide before beginning daily work or every 6 to 8 hours. All inner parts must be lubricated before storing for longer periods of time in order to prevent rusting. It is recommend to check the vanes and bearings at regular intervals. Store pneumatic tools in dry rooms only.

Lubricating oils to be used:
Generally SAE 5 W to SAE 10

For gearless impact wrenches and small grinders, only SAE 5 W

For damp compressed air, oils are to be used that take up water (without losing the lubricating effect) and that contain anticorrosive additives. At lower temperatures (especially for work outside) it may be necessary to use an antifreeze lubricant (e.g., Kilfrost, BP Energol AX 10, Kompranol N 74).

For saw-chain lubrication on chain saws:

Machine oil **with adhesive additive**, viscosity c ST 49-55' (6.5-7,5 E) / 50° C

Greases (free of resins and acids)

Multi-purpose greases for antifriction and friction bearings and gears

Special greases for high-speed miter gears

Designation in accordance with DIN 51502
Consistency class (DIN 51818)
Saponification type
Dripping point
Worked penetration
Temperature range

KL 2 K
2
lithium
185° C
265 to 295
-25° C to 125° C

G 00 h
00
sodium
145° C
400 to 410
-25° C to + 100° C



Disassembly and Re-assembly

Disassembly should be done only according to the sectional drawing.

Disassembly of Motor – changing vanes and elastic springs -

Take off gearbox housing item 35 with spur-gear stage and planetary-wheel stage after loosening screws item 44 and 46. If the planetary-wheel stage with pinion item 29 is remaining in the motor housing item 1, pull out them completely. To this light tapping with a rubber or plastic hammer on housing edge of the motor is helpful to loosen bearing washer item 30 and gear rim item 19. After removing screws item 13 (secured with Loctite) inner parts of motor can be pulled out. Doing this also light tapping on housing edge is helpful to loosen those parts.

After taking off motor cover item 5, remove end plate item 4, spacer item 47 and cylinder bushing item 2 from rotor item 6 as well as end plate item 3 and spacer item 10.

Take out vanes item 7 with elastic springs item 8 of rotor slots. If necessary, pull out ball bearing item 11 of motor housing item 1. Loosen screw item 17, remove damping cap item 15, spacer item 53, muffler item 48 and screw out nipple item 14.

Gearbox

a) Planetary stage

Loosen snap ring item 37, pull out pinion item 29, remove ball bearing item 31 and bearing washer item 30 from planet carrier, as well as rim of the gear item 19.

Loosen snap rings item, 27, press planetary wheel bolts out of seats and remove double-planetary wheels with needle cages item 24.

b) Spur-gear stage

Remove snap ring item 41 and take off spur-gear item 36.

Loosen screws item 45 and take out gearbox cover item 42 and driving shaft item 50 with ball bearings item 43 as well as driving shaft item 38 of gearbox housing.

Re-assembly

Reassembly is undertaken essentially in the reverse order. Correct positioning of the motor is important. End play between rotor item 6 and the end plates items 3 and 4 should be approx. 0.04 mm in both ends. The chamfers of the spacers items 10 and 47 should point towards to centre of the rotor.

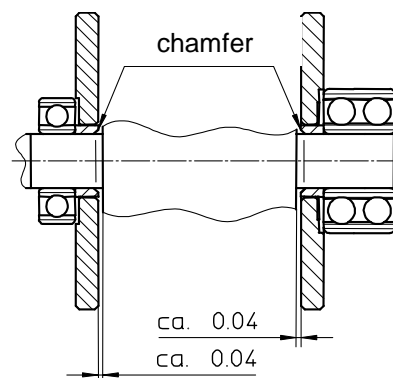

Remove any oil and resin residue from the rotor slots. The new vanes item 7 should fit easily into the slots. Grease ball bearings items 11 and 12.

After fasten the motor cover item 5 the rotor item 6 has to be turned easily by hand. If not, light tapping with a rubber hammer straight or lateral on motor housing item 1 is helpful to put the rotor item 6 in free-wheel position.

After completion of reassembly make functional gauging. Most it is enough to check free speed (220 rpm) and air consumption (0.9 m³/min) (see technical specification).

Spare Parts

Only original spare parts may be used. There is no warranty for damages and liability is disclaimed, if non-original spare parts and accessories are used.

| Greases (free of resin and acids) | Multi-purpose greases for friction bearings and gears |
|--|--|
| Designation according to DIN 51502 | KL 2 k |
| Consistency class DIN 51818 | 2 |
| Saponification type | Lithium |
| Dripping point | 185°C |
| Worked penetration | 265 - 295 |
| Temperature range | -25°C bis +125°C |

| Spare Part List | | | | |
|-------------------------------|------|------------------------------------|--------------------------|---------|
| Description: | | | Part and drawing number: | |
| Pneumatic Geared Motor | | | 3 1638 0010 | |
| Item | Qty. | Description | Part and drawing no. | Remarks |
| | | Pneumatic Geared Motor 3 1638 0010 | | |
| | | consisting of: | | |
| | 1 | Pneumatic Motor | 3 1638 1000 | |
| | 1 | Gearbox | 3 1638 4000 | |
| | | | | |
| | | | | |
| | | | | |
| | | | | |
| | | | | |
| | | | | |
| | | | | |
| | | | | |
| | | | | |
| | | | | |
| | | | | |
| | | | | |
| | | | | |
| | | | | |
| | | | | |
| | | | | |
| | | | | |
| | | | | |
| | | | | |
| | | | | |
| | | | | |
| | | | | |
| | | | | |
| | | | | |
| | | | | |
| | | | | |
| | | | | |
| | | | | |
| | | | | |
| | | | | |
| | | | | |
| | | | | |
| | | | | |
| | | | | |
| | | | | |
| | | | | |
| | | | | |
| | | | | |

Spare Part List

Description:

Pneumatic Motor

Part and drawing number:

3 1638 1000

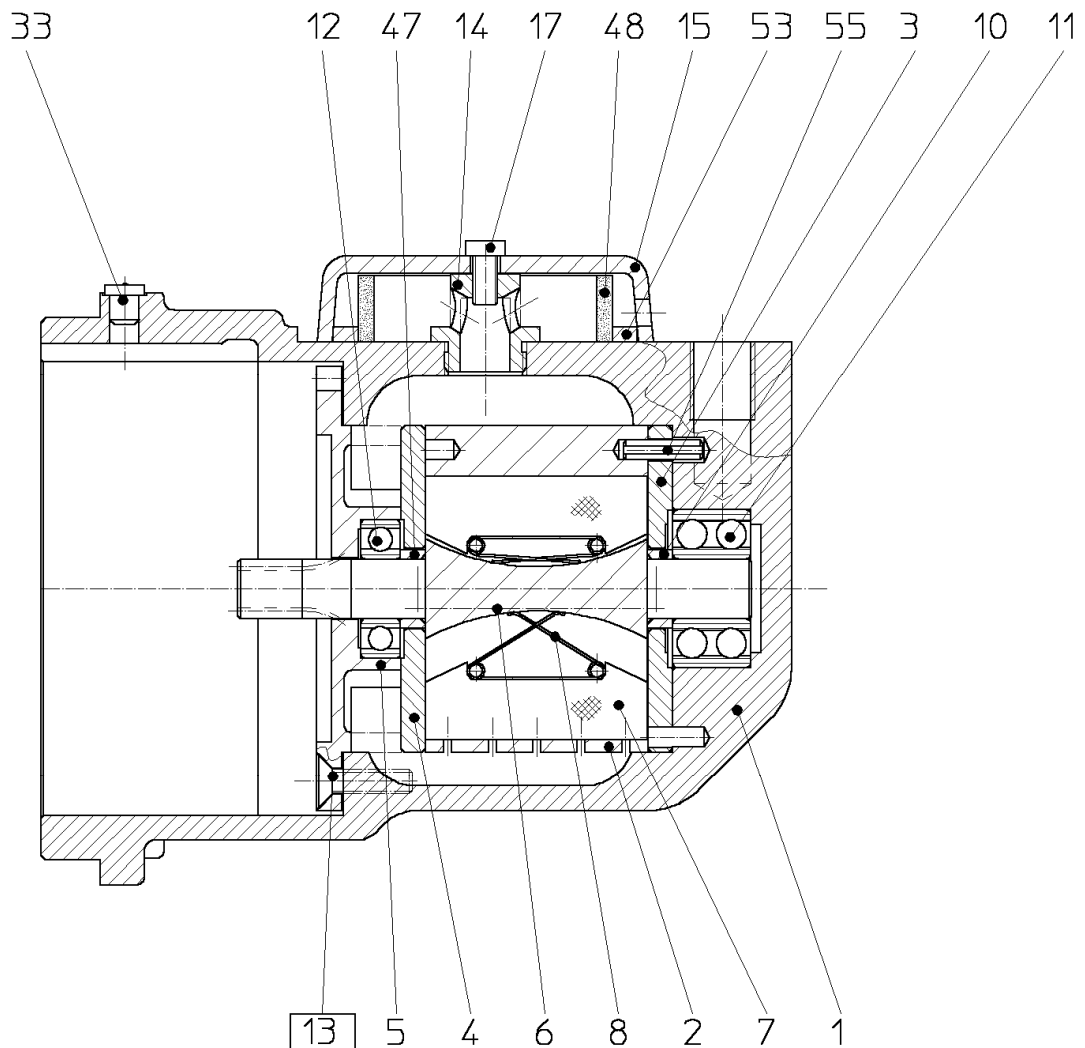

Locked with Loctite 243

| Spare Part List | | | | |
|-----------------------------|------|------------------------|--------------------------|---------------|
| Description: | | | Part and drawing number: | |
| Gearbox i= 30,966 | | | 3 1638 4000 | |
| Item | Qty. | Description | Part and drawing no | Remarks |
| 19 | 1 | Gear rim | 2 2001 4020 | |
| 20 | 1 | Planet carrier | 2 2003 4030 | |
| 22 | 2 | Double planetary wheel | 2 2001 4920 | |
| 24 | 4 | Needle cage | 9 1015 0140 | |
| 26 | 2 | Planet wheel bolt | 2 2001 4050 | |
| 27 | 2 | Snap ring | 9 1702 0020 | |
| 28 | 2 | Feather key | 9 1501 3350 | |
| 29 | 1 | Pinion | 3 1634 4040 | |
| 30 | 1 | Bearing disc | 3 1634 4060 | |
| 31 | 1 | Grooved ball bearing | 9 1007 0070 | |
| 32 | 1 | Grooved ball bearing | 9 1004 0040 | |
| 34 | 2 | Grooved ball bearing | 9 1004 0070 | |
| 35 | 1 | Gearbox housing | 3 1637 4010 | |
| 36 | 1 | Spur-gear | 3 1634 4140 | |
| 37 | 1 | Snap ring | 9 1702 0050 | |
| | 1 | Carrier shaft, assy. | 3 1636 4920 | |
| 38 | 1 | Carrier shaft | 3 1636 4120 | items 38 + 50 |
| 39 | 1 | Feather key | 9 1501 4060 | |
| 40 | 1 | Feather key | 9 1501 4100 | |
| 41 | 1 | Snap ring | 9 1702 0120 | |
| 42 | 1 | Gearbox cover | 3 1637 4090 | |
| 43 | 1 | Felt ring | 9 1902 0120 | |
| 44 | 2 | Socket head screw | 9 1112 5070 | |
| 45 | 4 | Socket head screw | 9 1112 4070 | |
| 46 | 2 | Socket head screw | 9 1112 5080 | |
| 50 | 1 | Drive shaft | 3 1636 7020 | |
| 51 | 4 | Washer | 9 3302 0030 | |
| 52 | 4 | Hexagonal nut | 9 1203 0050 | |
| 54 | 1 | Feather key | 9 1501 4040 | |
| 60 | 1 | Sealing | 3 1638 4190 | |

Spare Part List

Description:

Gearbox

Part and drawing number:

3 1638 4000

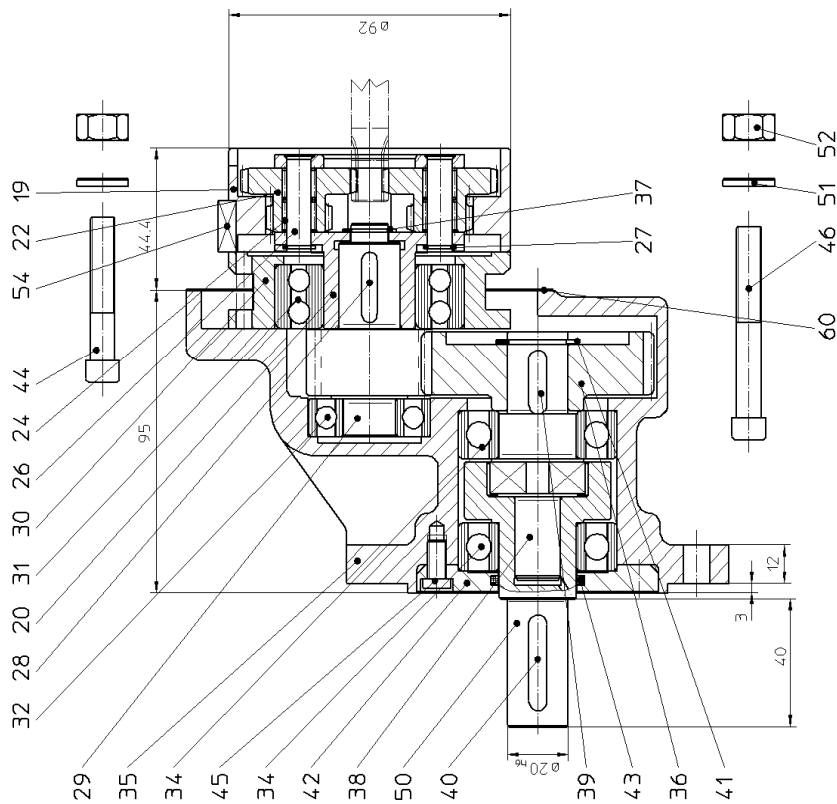
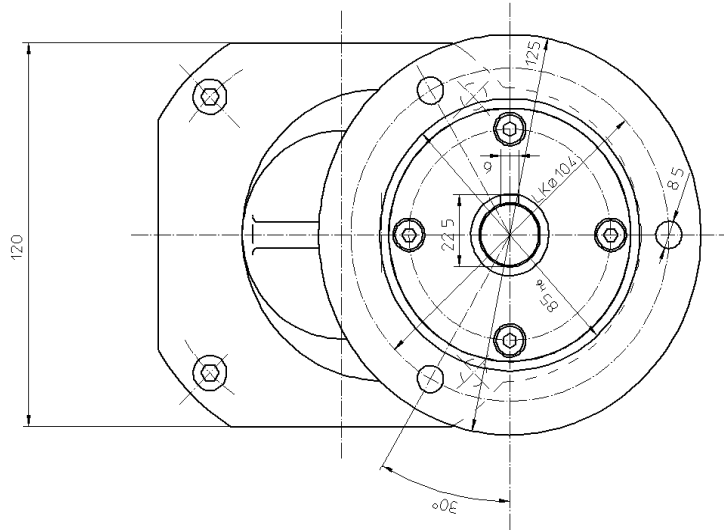

Installation Declaration
as defined in the European Union Machine Directive 2006/42/ EC

We, the company

SPITZNAS Maschinenfabrik GmbH, Fellerstraße 4, 42555 Velbert – Langenberg,

declare, that the following product

Machine constructive type: Pneumatic Geared Motor

Model: 3 1638 0010

complies with the provisions of the **European Machine Directive 2006/42/ EC** and conforms to the following standards or normative documents:

DIN EN ISO 12100

Requirement for the operation of this motor is that the complete machine, into which it is installed, corresponds to the regulations of the European Union Machines Directive, the harmonised standards, the European standards or the relevant national security standards.

Name of the authorized person for documentation: Mr. Simon Witt

Address of the authorized person for documentation: see manufacturer's address

D-42555 Velbert, 08.10.13