

**Pneumatic
Chain Saw
for industry
Type 5 1026
Tech. Doc. No. 519**



Illustration can differ from the original

**Repair Manual and
Spare Parts List**

Spare Parts and Accessories

Only genuine spare parts may be used. There is no warranty for damages and liability is disclaimed, if non-original spare parts and accessories are used.

Authorized personnel only is allowed to repair the machine.

REPAIR INSTRUCTION

Disassembly

- Disconnect machine from the air supply before starting.
- Push brake lever item 36 forward.
- Pull off socket head screw item 87 with spring washer item 86 and chain cover item 85.
- Pull chain bar and chisel chain with saw chain protection off the guide item 52.
- Remove strip item 56 by unscrewing the socket head screw item 42.
- Open tank cover item 91, drain off oil and dispose appropriately.
- Unscrew items 23- 29.
- Pull off brake lever item 36 (in actuated position) and feather key item 37 from the switch item 35.
- Unscrew socket head screws item 90 and pull out handle item 89 completely.
- Pull off snap ring item 84.
- Remove stop discs item 81 und 83 with chain wheel item 82 from the rotor shaft item 65.
- Take out cover item 45 by unscrewing the counter sunk screws item 46.
- Pull off brake disc item 80 and feather key item 67 from rotor shaft item 65.
- Take out motor cover item 79 by unscrewing the socket head screws item 38.
- Take out pressure ring item 75 and Belleville spring washers item 74.
- Knock out items 60- 66, 68- 73, 77 and 78 to the motor side.
- Unscrew groove nut item 73 (left- hand thread) and cap nut item 71 (right- hand thread).

- Take items 40, 41 and 44 (glued) out of the rocker item 32 by unscrewing the socket head screws item 38.
- Dismount brake band item 40 by unscrewing the socket head screw item 44 (glued).
- Remove tension spring item 39.
- Pull off snap ring item 33.
- Dismount item 32, 34 and 35.
- Replace bearing bolt item 30 (glued) und rocker item 32.
- Unscrew socket head screw item 58.
- Dismount interception item 57.
- Dismount items 52 to 55.
- Hexagonal nuts item 54 are glued.
- Dismount items 47 to 51.
- Hexagonal nut item Pos. 49 is glued.
- Pull out valve pin item 21.
- Knock out centre groove pin item 11.
- Remove valve lever item 7.
- Pull off snap ring item 10.
- Pull out valve piston item 6.
- Unscrew items 13 to 16.
- Button item 13 and locking screw item 16 are glued.
- Unscrew thread bushing item 20 (glued).
- Remove items 17 to 19.

Assembly

The assembly is done in reverse order.

The following has to be checked after the assembly:**a) Speed at 6 bar flow pressure (without chain bar and chain)**

- 6500 dry
- 8500 oiled

b) The release force of the brake lever (at standstill)

$F = 20- 60 \text{ N} / 2- 6 \text{ kg}$ below 45°

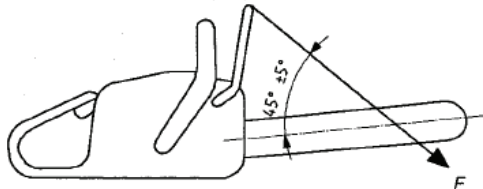
**c) Switch- off of the motor after brake release (brake lever) when control device is actuated.**

- When the brake lever item 36 is released and the valve lever item 7 is actuated, there must not come out any air of the air outlet.

d) Leakages

- There must not leak any oil or air, except from the air outlet and the outlet of the chain supply.

e) Initial position of the control device

- After release, the control device (valve lever item 7) must change into the initial position, without actuation by hand

f) Functioning of the braking process

- Start saw (wait for final start- up speed of the chain)
- Release brake (immediate stop of the chain)
- Release the valve lever (Switch the saw off)
- Pull the brake lever towards you (release of the brake)

Spare Parts List					
Description:				Part and drawing number:	
Pneumatic Chain Saw				5 1026	
Item	Qty.	Description	Part and drawing no.		Remarks
		5 1026 0010 consisting of:			
	1	Chain saw basic type	5 1026 0000		
	1	Chain bar 43 cm	5 1005 7120	*	
	1	Chisel chain 43 cm	5 1007 9930	*	
	1	Chain guard 45 cm	5 1003 9060		
	1	Screw driver hexagonal	9 1314 0030		
	1	Wrench	9 1316 0080		
85	1	Chain cover	5 1026 7310		
94	1	Plug	5 1026 7650		
95	2	Sound absorber	5 1026 2140		
96	1	Sound absorber	5 1026 2130		
	1	Connecting nipple R 3/4"	9 2205 2070		
	1	Connecting nipple NPT 3/4"	9 2205 0610		
		5 1026 0050 like 5 1026 0010, but with:			
	1	Chain bar 63 cm	5 1005 7140	*	
	1	Chisel chain 63 cm	5 1007 9940	*	
	1	Chain guard 63 cm	5 1005 9200		
		5 1026 0070 like 5 1026 0010, but with:			
	1	Chain bar 27 cm	5 1005 7160	*	
	1	Chisel chain 27 cm	5 1007 9960	*	
	1	Chain guard 45 cm	5 1003 9060		

Spare Parts List					
Description: Pneumatic Chain Saw				Part and drawing number: 5 1026	
Item	Qty.	Description	Part and drawing no.		Remarks
1	1	Motor housing, assy.	5 1026 1910		
5	1	Pressure spring	9 1803 3810		
6	1	Valve piston	5 1026 3010		
7	1	Valve lever	5 1026 6430		
8	3	O-ring	9 1901 2120	*	
10	1	Snap ring	9 1703 0360		
11	1	Grooved pin	9 1627 0140		
12	1	Threaded pin	9 1147 2010		
13	1	Locking pin	5 1026 3020		
14	1	Button	5 1026 3030		
15	1	Pressure spring	9 1803 5190		
16	1	Locking screw	5 1026 3040		
17	1	Gasket	9 1903 0990	*	
18	1	Steel ball	9 1017 0070		
19	1	Pressure spring	9 1803 0500		
20	1	Threaded bushing	5 1026 3050		
21	1	Valve pin	5 1026 3060		
22	1	O-ring	9 1901 9800	*	
23	2	Adjusting screw	9 1151 9070		
24	3	Gasket	9 1903 0260	*	
25	3	Locking screw	9 1150 9020		
27	1	Steel ball	9 1017 0200		
28	1	Pressure spring	9 1803 3380		
29	1	Threaded pin	9 1140 5080		
30	1	Bearing bolt	5 1026 2010		
31	1	Thread bolt	5 1026 2020		
32	1	Compensator	5 1026 7100		
33	1	Snap ring	9 1702 0010		
34	1	Connection joint	5 1007 9100		
35	1	Actuating lever, assy.	5 1026 2030		
36	1	Brake lever	5 1026 6800		
37	1	Feather key	9 1501 2100		

Spare Parts List					
Description:				Part and drawing number	
Pneumatic Chain Saw				5 1026	
Item	Qty.	Description	Part and drawing no.		Remarks
38	6	Socket head screw	9 1112 4150		
39	1	Tension spring	9 1804 0200		
40	1	Brake band	5 1026 1320		
41	1	Holder	5 1026 2040		
42	4	Socket head screw	9 1112 4020		
44	1	Socket head screw	9 1110 3010		
45	1	Cover	5 1026 7640		
46	5	Counter sunk screw	9 1113 2060		
47	1	Socket head screw	5 1026 2050		
48	1	Spring lock washer	9 3314 0070		
49	1	Hexagonal nut	9 1210 0030		
50	1	Feather key	9 1501 9060		
51	1	Adjustment wheel	5 1026 2060		
52	1	Guide	5 1026 7040		
53	1	Thread bolt	5 1026 2080		
54	1	Hexagonal nut	9 1203 0050		
55	1	Spring lock washer	9 3314 0320		
56	1	Spike racking	5 1026 7160		
57	1	Chain catching device	5 1026 7130		
58	1	Socket head screw	9 1112 4090		
59	1	Square nut	5 1026 2090		
60	1	End plate	51025 1100		
61	1	Grooved ball bearing	9 1005 0090		
62	1	Cylinder bushing	5 1020 1020		
63	1	Tension sleeve	9 1630 0300		
	1	Rotor, assy.	5 1026 1930		Item 64-65
64	1	Rotor	5 1025 1030		
65	1	Rotor shaft	5 1026 1040		
66	1	Feather key	9 1501 3430		
67	1	Feather key	9 1501 3050		
68	5	Vane	5 1007 1050	*	
69	1	End plate	5 1025 1110		

Spare Parts List

Description: Pneumatic Chain Saw	Part and drawing number: 5 1026

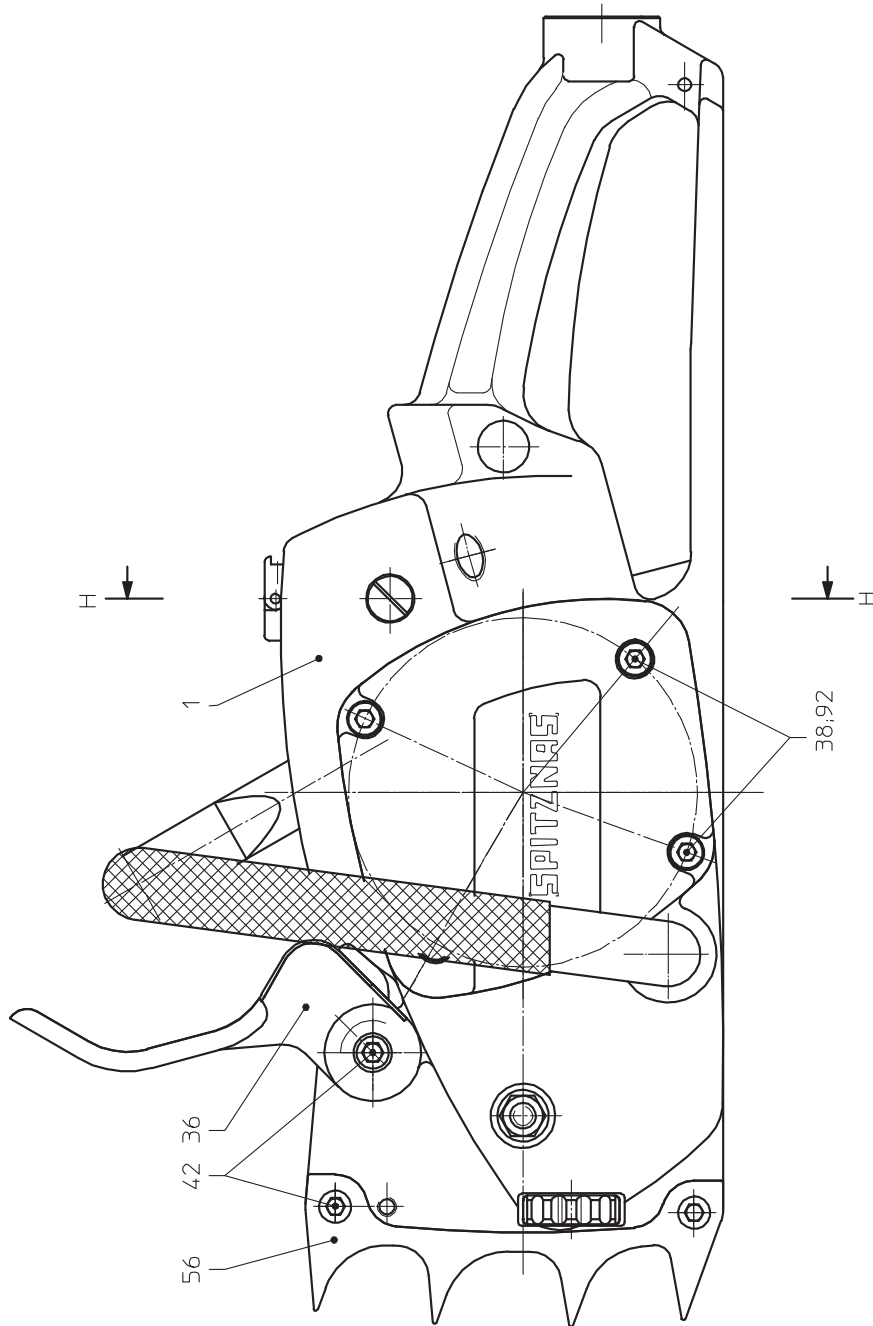

Spare Parts List

Description:

Pneumatic Chain Saw

Part and drawing number:

5 1026

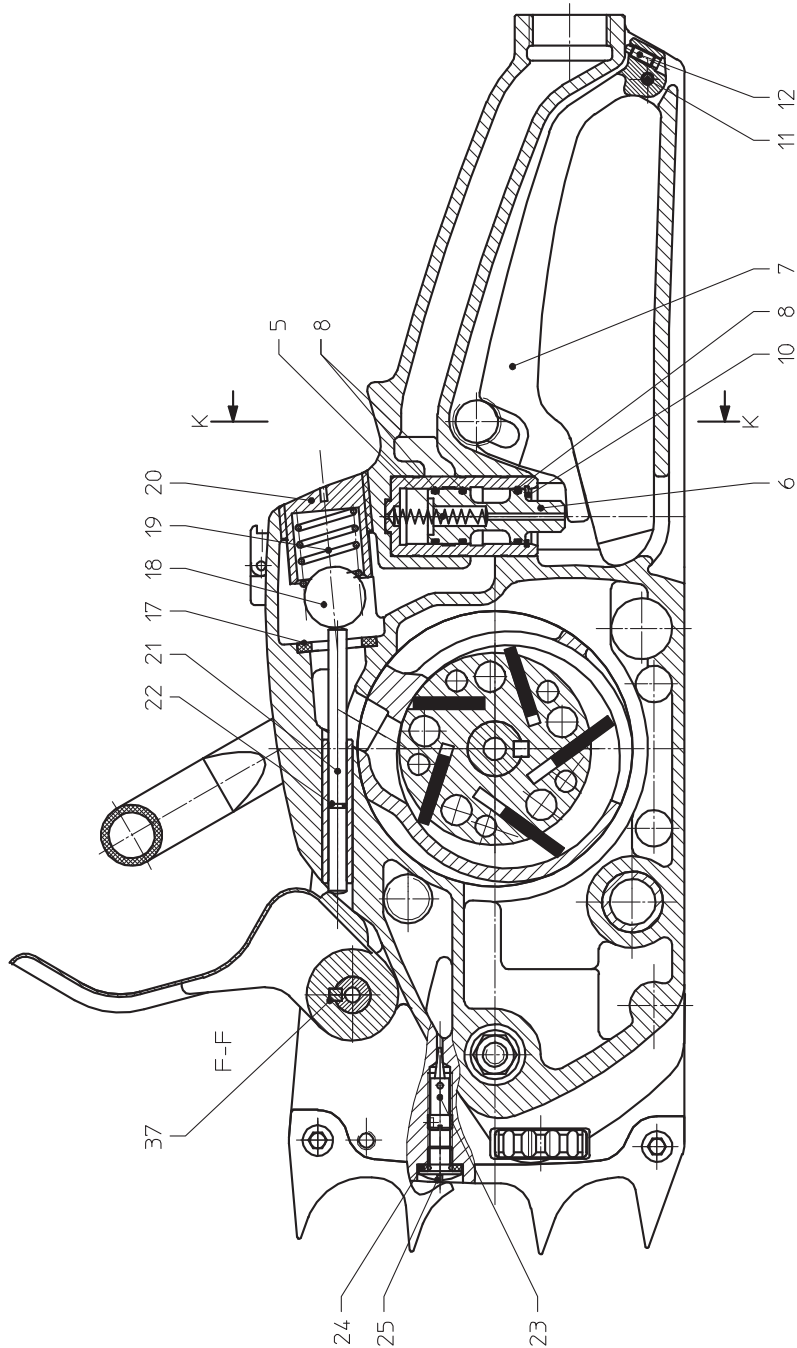

Spare Parts List

Description:

Pneumatic Chain Saw

Part and drawing number:

5 1026

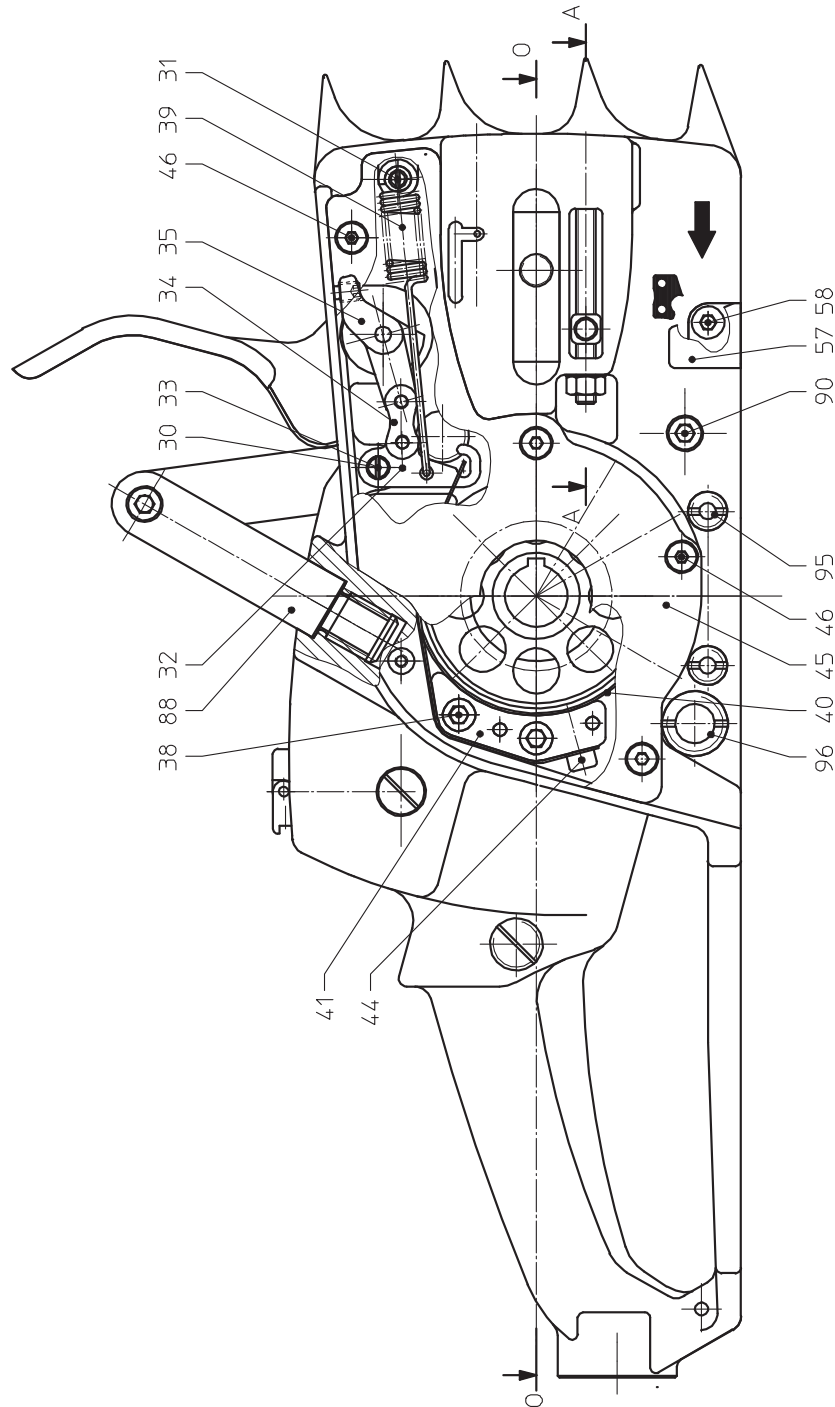

Spare Parts List

Description:

Pneumatic Chain Saw

Part and drawing number:

5 1026

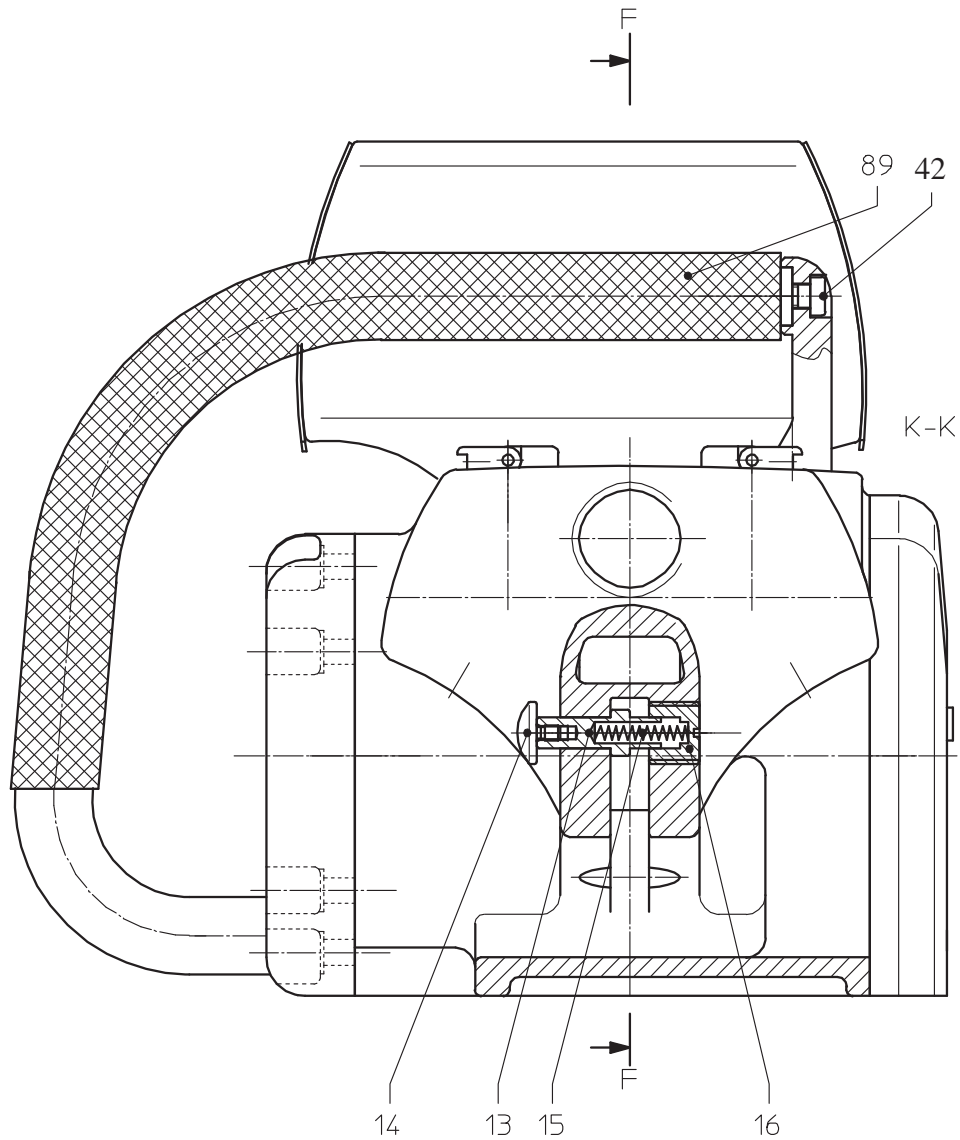

Spare Parts List

Description:

Pneumatic Chain Saw

Part and drawing number::

5 1026

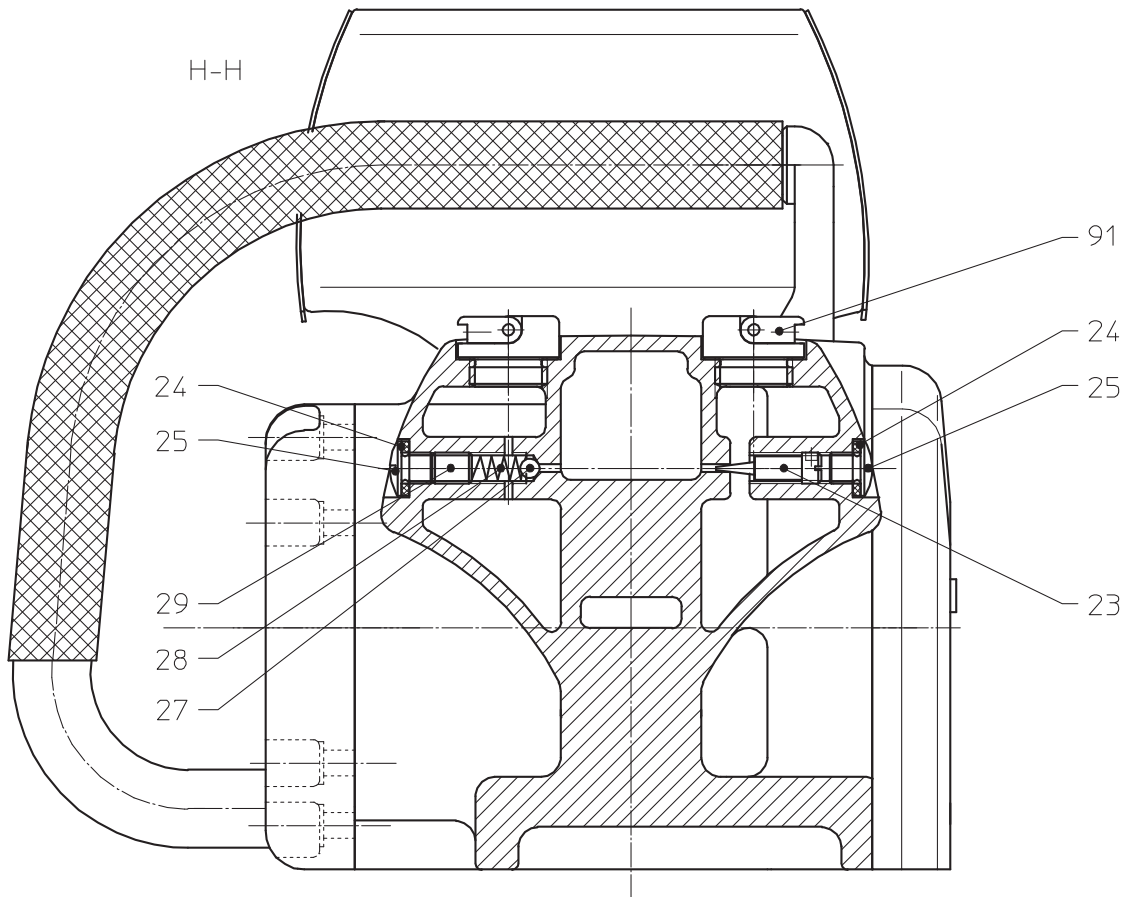

Spare Parts List

Description:

Pneumatic Chain Saw

Part and drawing number:

5 1026

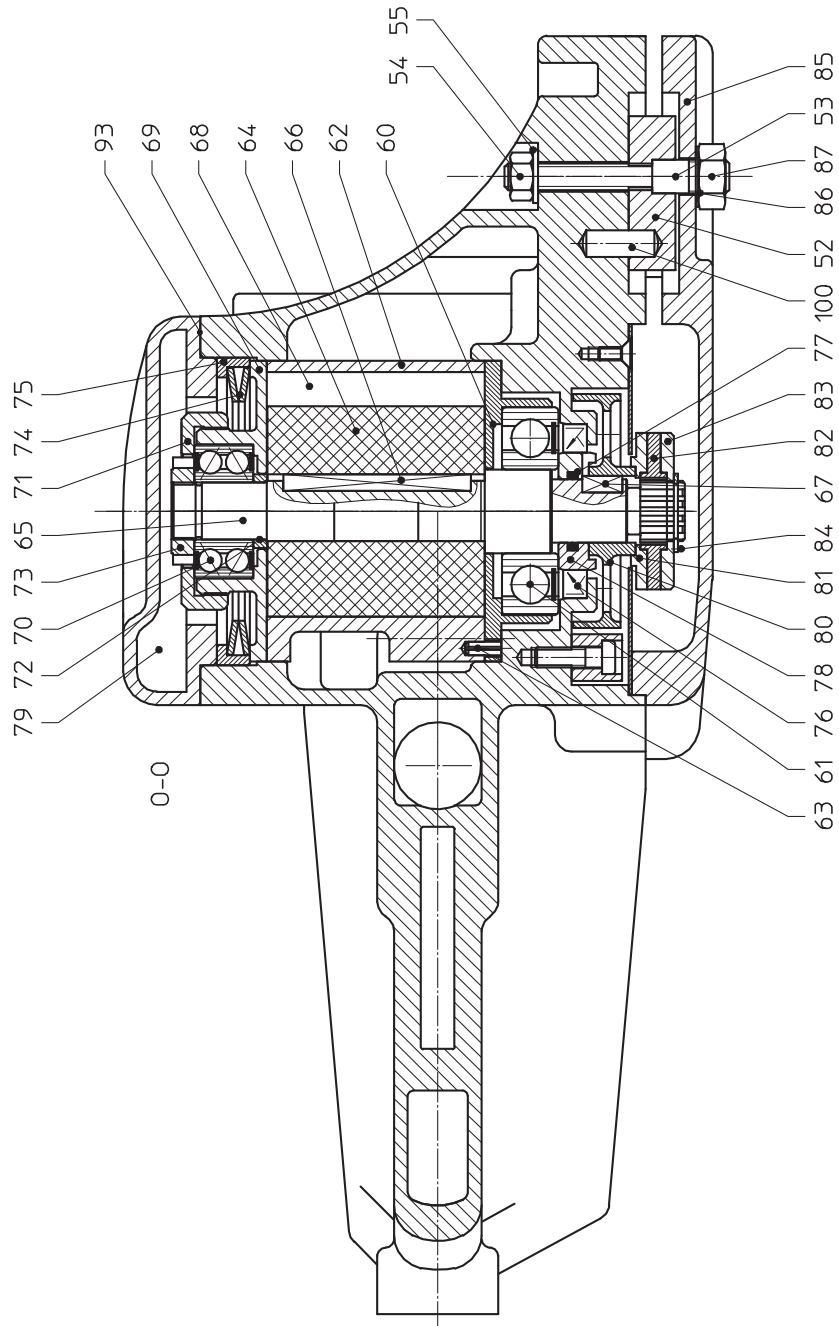

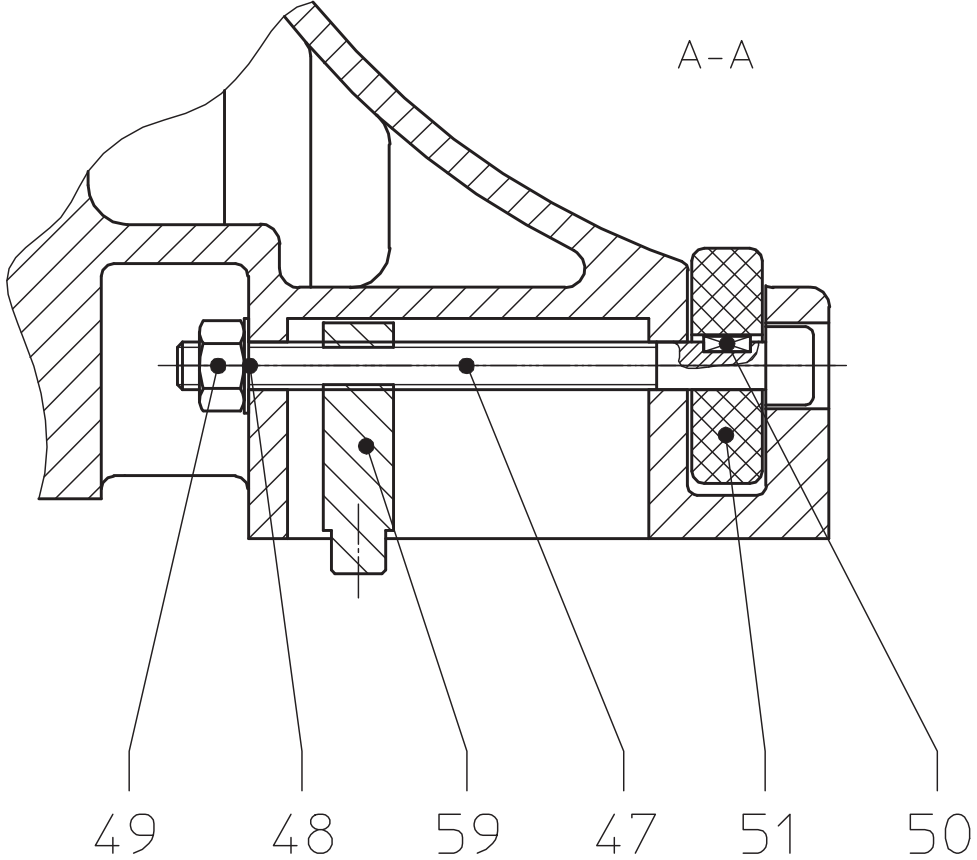
Spare Parts List	
Description:	Part and drawing number:
Pneumatic Chain Saw	5 1026
 <p style="text-align: center; margin-top: 10px;">49 48 59 47 51 50</p>	