

PLEASE SPECIFY TOOL MODEL # WHEN ORDERING PARTS

PARTS BREAKDOWN	Model #: 5 6003 0011	Bulletin #: 05-2020
PARTS LISTING	Description: AirBand Saw	Prepared By: JCN
	Date: 5/15/2020	

**5 6003 0011 AirBand Saw –
 Motor Parts Breakdown**

**5 6003 0011 AirBand Saw –
 Head Parts Breakdown**

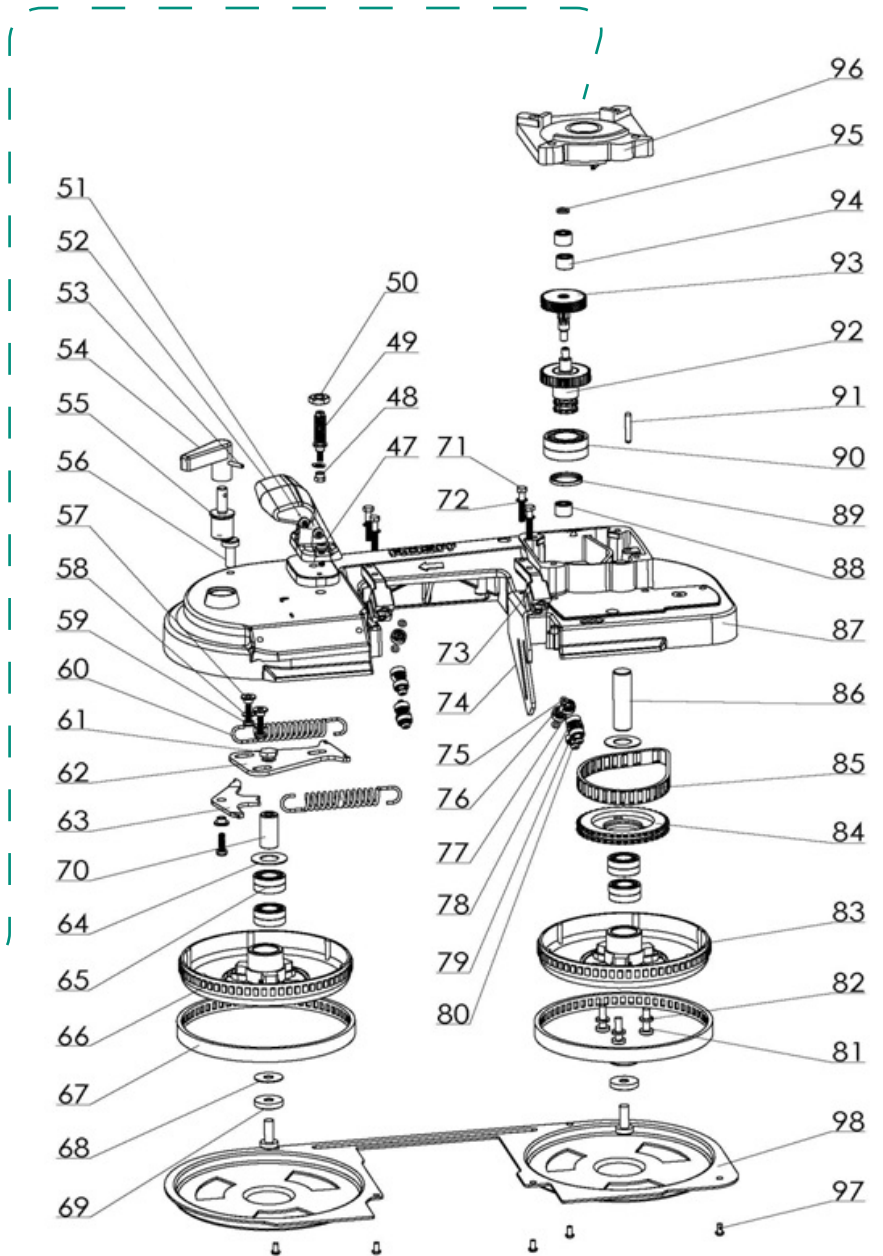
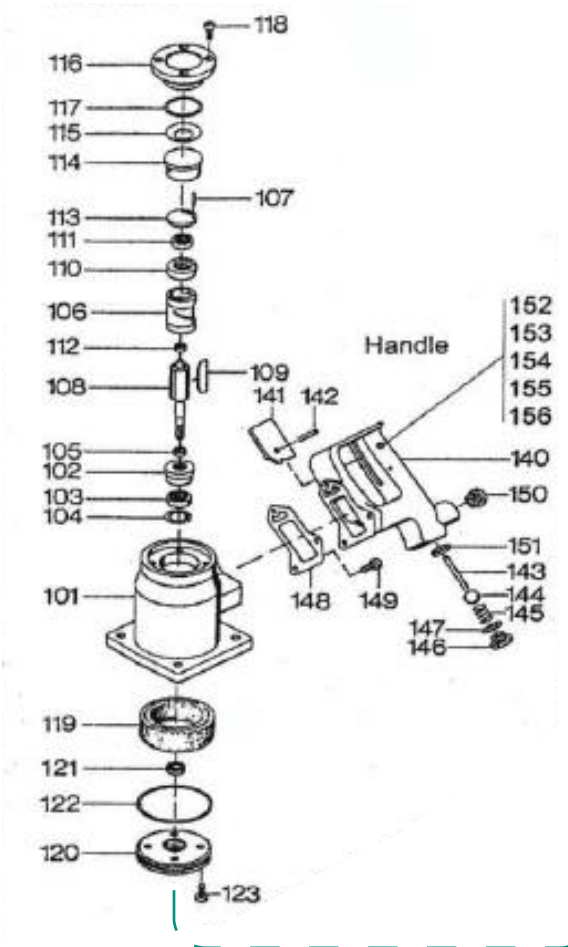

PLEASE SPECIFY TOOL MODEL # WHEN ORDERING PARTS

PARTS BREAKDOWN	Model #: 5 6003 0011	Bulletin #: 05-2020
PARTS LISTING	Description: AirBand Saw	Prepared By: JCN
	Date: 5/15/2020	

5 6003 0011 AirBand Saw Motor – PARTS LIST

No.	Order No.	Description	No.	Order No.	Description
101	5 6003 1910	Motor Housing	121	9 1905 0250	Sealing ring
102	5 6003 1100	End Plate	122	9 1901 2430	O Ring
103	9 1001 0050	Grooved Ball Bearing	140	5 6003 6010	Handle
104	9 1703 0040	Ring, snap	141	5 6003 3040	Valve Trigger
105	2 2404 1080	Spacer/shim	142	9 1641 0020	Pin, Notched
106	3 8636 1020	Cylinder Bushing	143	9 1637 1730	Pin, cylindrical
107	9 1619 0700	Pin	144	9 1017 0080	Ball
108	5 6003 1030	Rotor	145	9 1803 0250	Spring, Compression
109	3 8601 1050	Vane (5 Required)	146	9 1171 9060	Screw Plug
110	2 2404 1110	End Plate	147	9 1901 2320	O Ring
111	9 1001 0030	Grooved Ball Bearing	148	5 6003 6060	Sealing
112	1 1101 0030	Spacer/Shim	149	9 1112 4020	Screw
113	3 8636 1120	Cover	150	9 2203 0210	Nipple
114	5 6003 1180	Cap	151	9 1903 0160	Sealing
115	9 1801 0400	Spring, Belleville	152	5 6011 3170	Guiding Bushing
116	5 6003 1130	Motor Cover	153	5 6011 3150	Lock Bolt
117	9 1901 2370	O Ring	154	9 1803 3360	Compression Spring
119	1 2034 6100	Sound Absorber	155	5 6011 3160	Bushing
120	5 6003 1150	Motor Cover	156	9 1166 0170	Screw



PLEASE SPECIFY TOOL MODEL # WHEN ORDERING PARTS

PARTS BREAKDOWN	Model #: 5 6003 0011	Bulletin #: 05-2020
PARTS LISTING	Description: AirBand Saw	Prepared By: JCN
	Date: 5/15/2020	

5 6003 0011 AirBand Saw Head – PARTS LIST
(Old No. for 5 6003 0010 – Schematic/Order No.)

No.	Order No.	Old No.	Description	Pcs	No.	Order No.	Old No.	Description	Pcs
47	1102 20146	10 / 9 1164 0410	Screw with cross slot	5	78	1102 20159	22 / 9 1029 0190	Bearing	8
49	1102 20148	84 / 5 6003 7030	Adjusting bolt	1	79	1102 20613		Elastic washer	4
50	1102 20193	83 / 5 6003 7170	Nut	1	80	1102 20157	20 / 9 1164 0420	Screw	4
51	1102 20169	37 / 9 1164 0440	Screw with cross slot	2	81	1102 20178	55 / 9 1164 0480	Screw	3
52	1102 20145	9 / 5 6003 6900	Handle	1	82	1102 20177	56 / 9 3314 0250	Spring lock washer	3
53	1102 20108	80 / 9 1630 0150	Cylinder pin	1	83	1102 20154		Idle pulley	1
54	1102 20147	11 / 5 6003 7020	Tensioning lever	1	84	1102 20175	54 / 5 6003 7150	Chain wheel	1
55	1102 20148	11A / 5 6003 7030	Adjusting bolt	1	85	1102 20174	53 / 5 6003 7140	Chain	1
56	1102 20146	57 / 9 1164 0410	Screw with cross slot	3	86	1102 20153		Idler shaft	1
57	1102 20155	14 / 9 3325 0820	T spacer bush	3	87	1102 20144	8 / 5 6003 7010	Housing, Assy.	1
58	1102 20170	38 / 9 3325 0870	Washer	3	88	1102 20614		Bearing	1
59	1102 20610		Screw with cross slot	3	89	1102 20615		Seal	1
60	1102 20172	48 / 9 1808 0240	Tensioning spring	2	90	1102 20616		Bearing	1
61	1102 20146	10 / 9 1164 0410	Screw with cross slot	1	91	1102 20166	28 / 9 1637 1750	Pin	1
62	1102 20168	36 / 5 6003 7940	Washer	1	92	1102 20182	61 / 5 6003 4910	Chain wheel with sprocket	1
63	1102 20149	12 / 5 6003 7040	Bow	1	93	1102 20185	65 / 5 6003 4040	Intermediate gear	1
64	1102 20170	38 / 9 3325 0870	Sealing	2	94	1102 20181	60 / 9 1029 0170	Bearing	2
65	1102 20152	15 / 9 1029 0160	Bearing	4	95	1102 20192	81 / 9 3325 0860	Washer	3
68	1102 20179	58 / 9 3325 0840	Washer	2	96	1102 20187	66 / 5 6003 4920	Intermediate plate	1
69	1102 20180	59 / 9 3325 0850	Guard Plate	2	97	1102 20617		Hexagon head screw	5
70	1102 20153	16 / 5 6003 7080	Sleeve	1	98	1102 20196		Cover plate	1
71	1102 20611		Hexagon head screw	4					
72	1102 20612		Internal washer	4					
73	1102 20160	23 / 5 6003 7120	Guide holder	2					
74	1102 20156	19 / 5 6003 7100	Spacing block	1					
75	1102 20162	24 / 9 1625 0020	Pin	4					
76	1102 20163	25 / 9 3325 0830	Washer	2					
77	1102 20164	26 / 9 1029 0200	Ball bearing	2					

PLEASE SPECIFY TOOL MODEL # WHEN ORDERING PARTS

PARTS BREAKDOWN	Model #: 5 6003 0011	Bulletin #: 05-2020
PARTS LISTING	Description: AirBand Saw	Prepared By: JCN
	Date: 5/15/2020	

5 6003 0011 - Bandsaw Blades

Order No.	Length	Dimensions Teeth/Inch	Thickness	Max. Dia. of Cut
9 2506 0040	44-7/8"	8/12	0.025"	Cuts material 1/2" and thicker
9 2506 0030	44-7/8"	10/14	0.025"	Cuts material 3/16" to 1/2" thick
9 2506 0020	44-7/8"	14	0.025"	Cuts material 3/16" to 1/2" thick
9 2506 0010	44-7/8"	18	0.025"	Cuts material 1/8" to 1/4" thick