

CS Unitec, Inc.
 22 Harbor Avenue
 Norwalk, CT 06850
 Tel: 800-700-5919
 Fax: 203-853-9921

SPARE PARTS LIST

DESCRIPTION :
Core Drill Unit
 2.8 kW

PART NUMBER / DRAWING NUMBER :
2 1328 0050

Page: 3 of 4

Date: 06/06

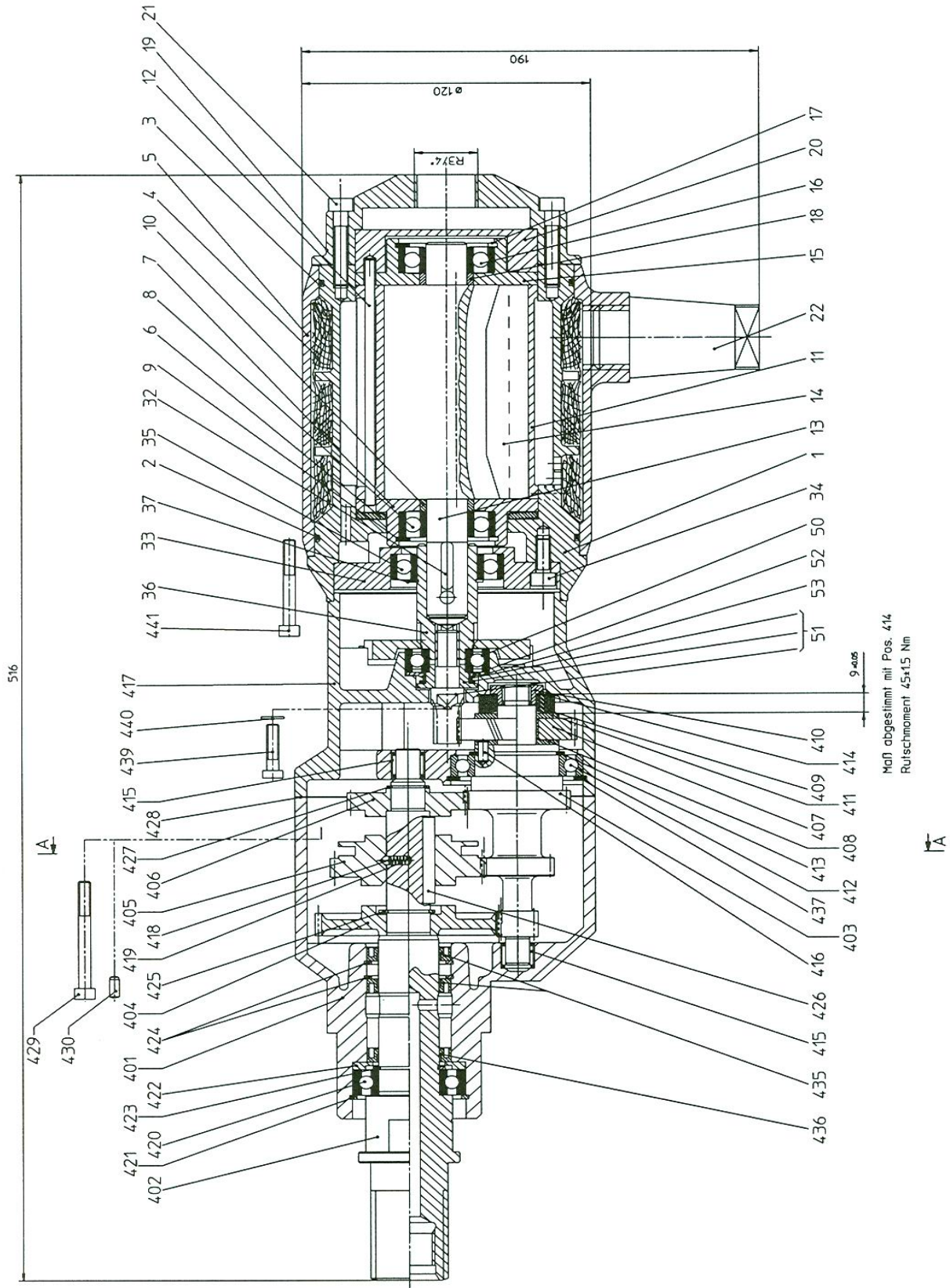

CS Unitec, Inc.
22 Harbor Avenue
Norwalk, CT 06850
Tel: 800-700-5919
Fax: 203-853-9921

SPARE PARTS LIST

DESCRIPTION :

Core Drill Unit
2.8 kW

PART NUMBER / DRAWING NUMBER:

2 1328 0050

Page : 4 of 4

Date: 06/06

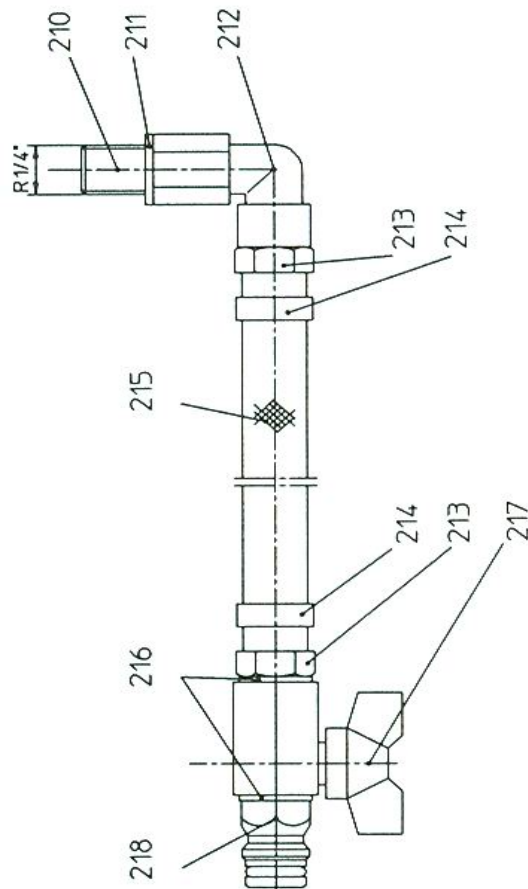
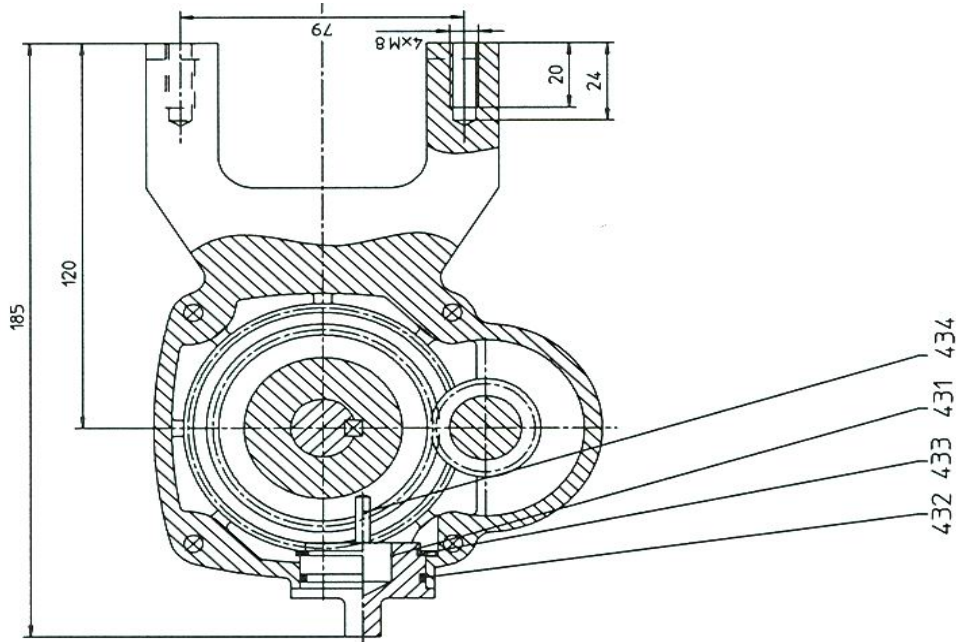

Drill- Stand BST 300 V / U

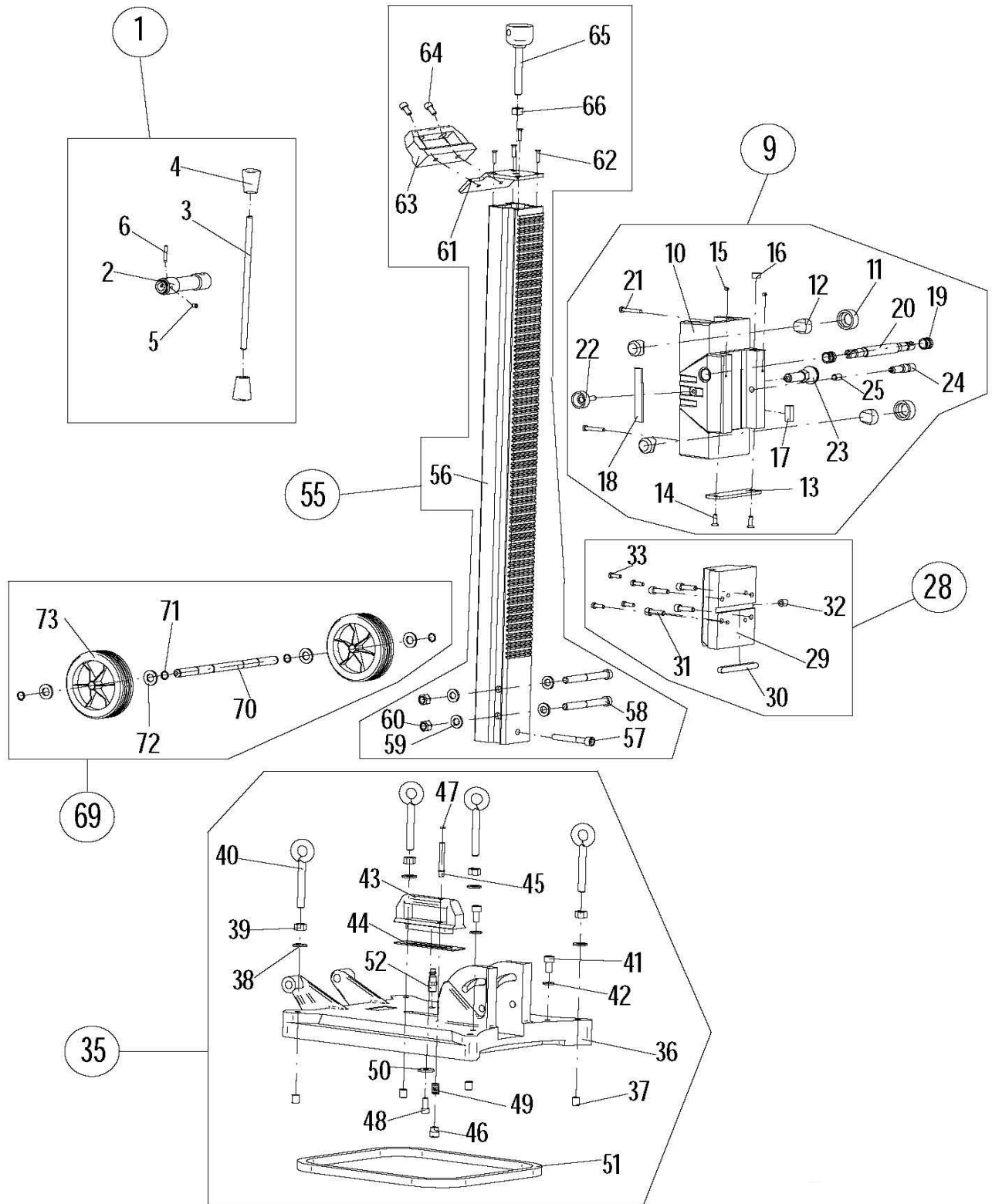

Not responsible for typographical errors.

<u>POS. NO.</u>	<u>ITEM NO.</u>	<u>DESCRIPTION</u>
	2 1315 4960	Gearshift Lever Assembly
	2 1317 4920	Countershaft Assy. consist of Items 403-433
	2 1328 1000	Motor Complete
	2 1328 4000	Gearbox Complete
	9 3606 0380	Water Hose
10 + 18	5 1003 1090	Shim
2 + 3	9 1901 3400	O-Ring
35 + 420	223 158	Bearing
37 + 423	223 344	C-Clip
416 + 430	9 1619 1300	Pin
8 + 16	9 1004 0040	Bearing
9 + 17	9 1703 0120	Snap Ring 4-26-16-003-00-2
1	2 1315 1010	Motor Housing
4	1 2034 6100	Sound Absorber
5	2 1315 1120	Rotary Sleeve
6	9 1802 0480	Spring, Belleville
7	3 6412 1110	End Plate
11	3 6412 1020	Cylinder Bushing
12	9 1637 1850	Stop Pin
13	2 1315 1030	Rotor
14	3 6412 1050	Vane
15	3 6412 1100	End Plate
19	3 6415 1130	Motor Cover
20	3 6415 1160	Cover
21	9 1110 4060	SCREW
22	9 3801 1040	Muffler
32	9 1501 3470	Feather Key
33	2 1315 4180	Bearing Housing
34	9 1110 4020	Fillister Head Screw
36	2 1315 4170	Pinion Shaft
50	117 668	Ball Bearing
51	256 757	Pinion REPLACES # 2 1315 4950
52	9 1908 1340	End Plate
53	9 1908 1350	Seal, Paper
210	9 2126 0150	Connecting Nipple
211	256 982	Seal
212	9 2209 0130	Elbow

CS Unitec, Inc.

22 Harbor Ave, Norwalk, CT 06850

Telephone: 203-853-9522 Toll Free: 800-700-5919 Fax: 203-853-9921

WebSite: www.csunitec.com E-Mail: info@csunitec.com

Not responsible for typographical errors.

POS. NO.	ITEM NO.	DESCRIPTION	
213	9 2109 0050	Nozzle	
214	9 2104 0010	HOSE CLAMP	
215	9 3602 0280	HOSE	
216	251 648	Valve Ring-#52662&65205	#9 2126 0140 & 9 2126 0120
217	9 2014 0900	Stop Valve	
218	251 650	Brass Nipple	Replaces 83000104 & 76RK497:
401	2 1327 4010	Bearing Housing	
402	2 1315 4270	SHAFT	
403	2 1317 4170	Gear Shaft	
404	253 895	Gear	
405	253 896	Gear	
406	253 897	Gear	
407	2 1320 4430	Spur Gear	
408	259 158	Washer Ring	
409	255 469	Spring Washer	
410	2 1327 0120	NUT	
411	253 164	Compression Washer, Core Drill	
412	9 1027 0530	Ball Bearing	
413	105 546	C-Clip	
414	253 165	Distance Ring	
414	253 166	Spacer	
415	242 942	Needle Cage	
417	2 1320 1010	Housing	
418	254 048	Ball	
419	254 049	Spring	
421	111 392	C-Clip	
422	254 101	Ring	
424	9 1703 0110	Retaining Ring	
425	256 115	C-Clip	
426	254 046	Key	
427	254 045	C-Clip	
428	2 1317 1190	Seal	
429	9 1110 3110	Screw	
431	253 910	Knob	
432	9 1901 3130	O Ring (See P/N 237 469)	4-06-12-060-00-1
433	255 648	C-Clip	
434	9 1637 2110	Dowel Pin	See P/N 255 649

CS Unitec, Inc.

22 Harbor Ave, Norwalk, CT 06850

Telephone: 203-853-9522 Toll Free: 800-700-5919 Fax: 203-853-9921

WebSite: www.csunitec.com E-Mail: info@csunitec.co

Not responsible for typographical errors.

POS. NO.	ITEM NO.	DESCRIPTION	
435	253 222	SEALING RING-# 41376,	9 1905 0050
436	253 219	Ring-#41377, # 9 1905 1230	
437	9 1703 0160	Snap Ring	
439	203 335	Screw	SEE # 9 1110 3100
440	107 727	Washer	
441	9 1110 3040	Screw	

CS Unitec, Inc.

22 Harbor Ave, Norwalk, CT 06850

Telephone: 203-853-9522 Toll Free: 800-700-5919 Fax: 203-853-9921

WebSite: www.csunitec.com E-Mail: info@csunitec.co

Not responsible for typographical errors.

POS. NO.	ITEM NO.	DESCRIPTION
31 + 48	80201147	SCREW
39 + 66	80201014	Nut
1	15200100	Handle Complete (Incl. 2-6)
2	796UN740	Handle Base
3	796UN746	Arm
4	85000193	Knob
5	85000157	Spring
6	80200627	Pin
9	79600780	Carriage Assembly (Items 10-25)
10	796UN780	Carriage
11	796UN765	Bushing Cap
12	796UN763	Bushing
13	796UN915	Plate
14	80201158	Sink Screw
15	80200758	Set Screw
16	85000153	Leveling Indicator
17	85000152	Level
18	796UN778	Clamping Piece
19	796UN770	Bushing
20	7300W730	Pinion Shaft
21	80201186	Cylinder Screw
22	85000189	Screw
23	85000191	Locking Nut
24	796UN735	Fastener
25	85000177	Helicoil
28	79600932	Adapter Plate Complete (29-33)
29	796UN932	Adapter Plate
30	80200613	Key
32	80201051	Bushing
33	80201124	Socket Head Screw
35	79600895	Base, Complete Incl. 36-52
36	796UN895	Base
37	85000163	Helicoil
38	80201381	Washer
40	80201144	Screw eye
41	80201146	Screw
42	80201380	Washer

CS Unitec, Inc.

22 Harbor Ave, Norwalk, CT 06850

Telephone: 203-853-9522 Toll Free: 800-700-5919 Fax: 203-853-9921

WebSite: www.csunitec.com E-Mail: info@csunitec.co

Not responsible for typographical errors.

POS. NO.	ITEM NO.	DESCRIPTION	
43	796UN813	Vacuum Handle	
44	83000066	Slot Cap Gasket	Replaces 796UN812
45	796UN650	Vacuum Release Button	
46	796UN814	Vacuum Stop	
47	83000083	Round Ring	
49	85000175	Spring	
50	80201372	Washer	
51	83000096	Base Gasket	
52	83000164	Connector	
55	79600950	Column Complete (Items 56-66)	
56	796UN950	Column	
57	80201139	Bolt	
58	80201188	Cylinder Screw	
59	80201388	Washer	
60	80201036	Hexagon Nut	
61	796UN934	Seizing Plate-REPLACE 796UN921	
62	80201168	Sink Screw	
63	796UN824	Handle	
64	80201160	Screw	
65	796UN928	Support-REPLACES 796UN921	
69	79600809	Wheel Axes complete	(Items 70-73)
70	796UN809	Wheel Axal	
71	80201318	Locking Ring	
72	80201352	Washer	
73	85000178	Wheels	

CS Unitec, Inc.

22 Harbor Ave, Norwalk, CT 06850

Telephone: 203-853-9522 Toll Free: 800-700-5919 Fax: 203-853-9921

WebSite: www.csunitec.com E-Mail: info@csunitec.co