

MAB 155



Cutter capacity
 1 1/2" dia.

Horizontal motor mount for drilling in tight spaces

Powerful • Reliable

- 9.25 Amp double-insulated motor
- Ultra compact, 7" high
- Ratchet-style advancing mechanism for work in spaces with limited clearance
- Lightweight, 24 lbs.
- Intelligent electronic torque control
- Designed for continuous use

Drill up to 1-1/2" dia.*

- Uses annular cutters up to 1-1/2" dia.

Integrated Safety

- Emergency-off function
- Internal cable routing
- Simple, ergonomic arrangement of controls for one-handed operation

Internal cable routing protects the motor power cord from external damage



Ratchet-style advancing mechanism for work in spaces with limited clearance.

Equipped with Electronic Safety Shutoff Sensor (see p. 25)

MAB 155 uses standard 3/4" shank annular cutters



Cutter Capacity



ø 1 1/2"

Stroke (length)



1 1/2"

Speed Range (RPM)



460

* Model MAB 155 accepts cutters with a 3/4" weldon shank and a maximum depth of cut of 1-1/2".

Switches for power and magnet adhesion are arranged for simple, uncomplicated operation.



MAB 155 Specifications

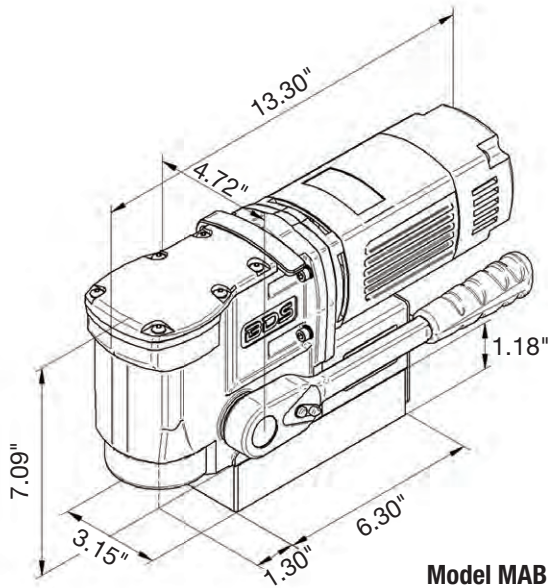

Model MAB 155

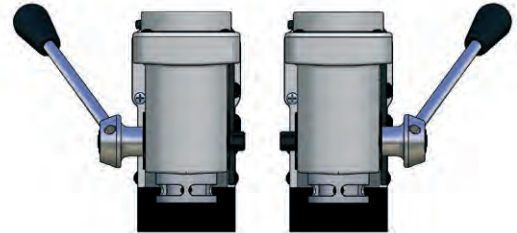

Advancing lever can be mounted on either the left or right side of the MAB 155.

MABasic 155 Specifications

Motor Power	9.25 Amp / 110 Volt
Weight	24 lbs.
Hole Capacity	1 1/2" dia.
Speed	460 RPM
Magnet Base Size	6 ⁵ / ₁₆ " L x 3 ³ / ₁₆ " W
Dimensions	7 ¹ / ₈ " H x 13 ⁵ / ₁₆ " L x 4 ³ / ₄ " W
Magnetic Force (1" plate)	2640 lbs.
Arbor Bore	3/4" Weldon Shank

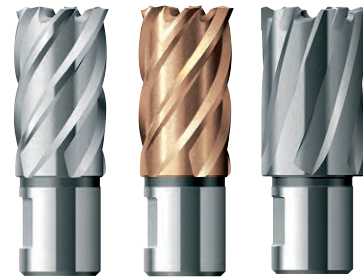

Model MAB 155 accepts cutters with 3/4" weldon shank. This unit has a maximum depth of cut of 1-1/2".

See pages 56-61 for our HSS, TiAIN and Carbide-tipped cutters.

Standard Equipment

- 1 Magnetic drilling machine
- 1 Pilot pin
- 1 Plastic carrying case
- 1 Safety chain
- 1 Hexagon socket screw key SW 4
- 1 Operating manual
- 1 Warranty certificate



Standard Equipment also includes safety strap, carabin hook and allen keys.

