

# MABasic 200



Cutter capacity  
1 3/8" dia.

**Heavy-duty, purpose-built, single-speed workhorse**

## Powerful • Reliable

- Strong 8.2 Amp motor
- Compact, lightweight and portable – 12-1/4" high, 27 lbs.

## Drill up to 1-3/8" dia.

- Uses annular cutters up to 1-3/8" dia.; 6-1/3" stroke
- Twist drilling capacity up to 1/2" dia.
- 3-1/3" stroke with included geared chuck
- Internal lubrication system



With included 1/2" geared chuck (IBC 18), this model easily converts to a standard drill press with a 3 1/3" stroke for conventional twist drills.

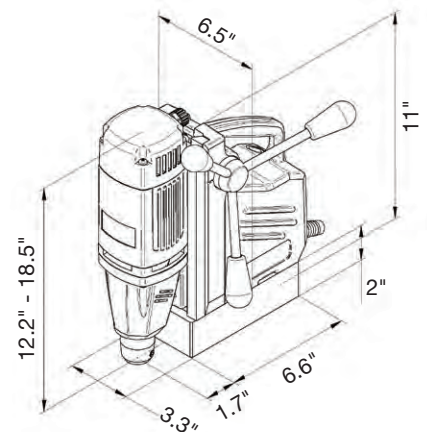

Equipped with Electronic Safety Shutoff Sensor (see p. 25)



**Standard Equipment** includes lubrication bottle, 3/4" weldon arbor, 1/2" geared chuck, safety strap, carabin hook, allen keys, pilot pin and carrying case.



## MABasic 200 Specifications

Motor Power	8.2 Amp / 110 Volt
Weight	27 lbs.
Hole Capacity	1 3/8" dia.
Twist Drill Capacity	1/2" dia.
Speed	450 RPM
Magnet Base Size	6 5/8" L x 3 1/3" W
Dimensions	12 1/4" H x 9" L x 6 1/2" W
Magnetic Force (1" plate)	3080 lbs.
Arbor Bore	3/4" Weldon Shank
Internal Lubrication	Oil Bottle Included

➤ Annular Cutters: pages 54-64 ➤ Accessories: pages 65-71