

MABasic 850



4-gear, powerful motor for demanding jobs

Powerful • Reliable

- 16 Amp double-insulated motor
- MT3 – 3/4" direct arbor with automatic cooling
- 19-3/8" high, 53 lbs.
- High-speed, 4-speed gearbox

Drill up to 3-1/16" dia.

- Uses annular cutters up to 3-1/16"; 10" stroke
- Twist drilling capacity up to 1-1/4" dia.
- Internal lubrication system



With included 3/4" chuck (IBC 21), this model easily converts to a standard drill press for conventional twist drills.

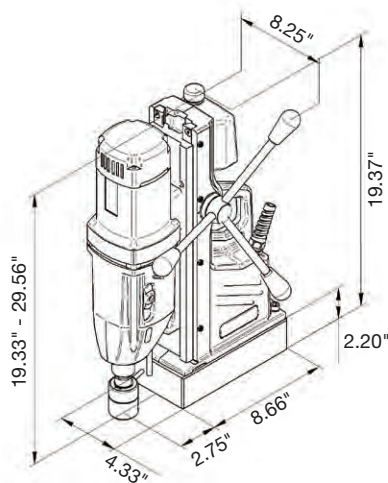

MABasic 850 Specifications

Motor Power	16 Amp / 110 Volt
Weight	53 lbs.
Hole Capacity	3 1/16" dia.*
Twist Drill Capacity	1 1/4" dia.
Speed	1: 110 RPM, 2: 175 RPM 3: 245 RPM, 4: 385 RPM
Magnet Base Size	8 5/8" L x 4 1/3" W
Dimensions	19 3/8" H x 11 5/8" L x 8 1/4" W
Magnetic Force (1" plate)	6000 lbs.
Arbor Bore	3/4" Weldon Shank
Spindle	MT3
Internal Lubrication	Included

* 3-1/16" cutters have 1-1/4" Weldon shank. Part No. ZIA 30/32 arbor is required.

Standard Equipment includes 3/4" geared chuck, safety strap, carabin hook, allen keys, pilot pin and carrying case.



➤ [Annular Cutters: pages 54-64](#) ➤ [Accessories: pages 65-71](#)