



Operation Manual & Parts List

Model CSH 160
18" Hand-Held Pneumatic Concrete Saw
and
Model CSH 135
14" Hand-Held Pneumatic Concrete Saw



CS Unitec, Inc.

22 Harbor Ave., Norwalk CT 06850 USA
4330 Center St., Deer Park, TX 77536 USA

Phone (800) 700-5919 or (203) 853-9522 • Fax (203) 853-9921
www.csunitec.com • e-mail: info@csunitec.com



AIR CONCRETE SAW

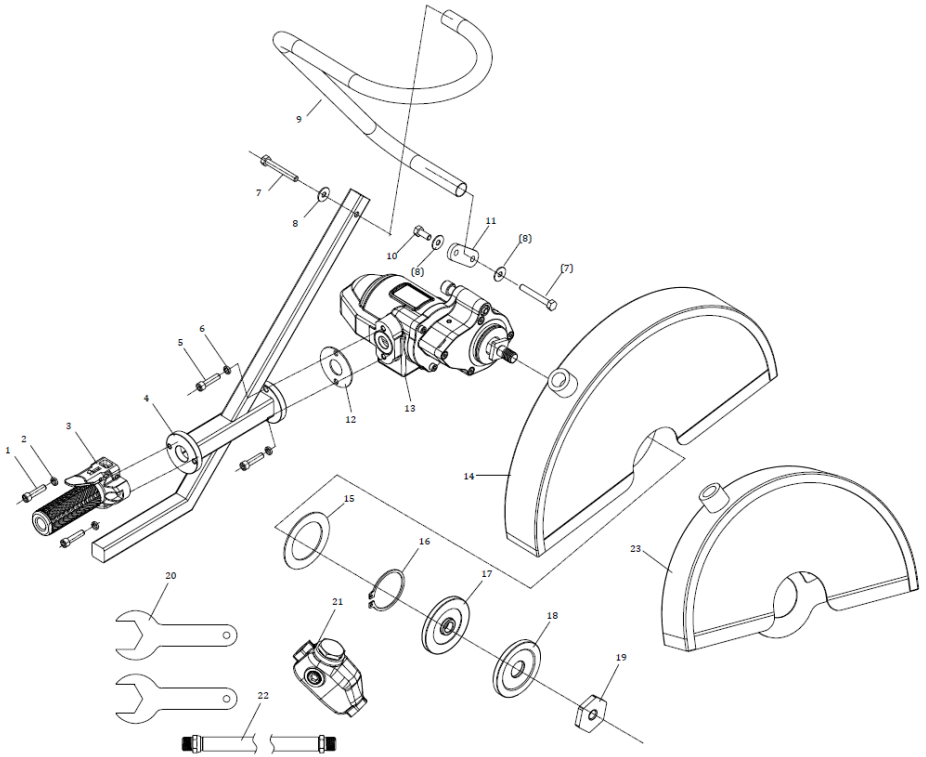

CS Unitec, Inc.

22 Harbor Ave., Norwalk CT 06850 USA
4330 Center St., Deer Park, TX 77536 USA

Phone (800) 700-5919 or (203) 853-9522 • Fax (203) 853-9921
www.csunitec.com • e-mail: info@csunitec.com



AIR CONCRETE SAW BILL OF MATERIALS			
ITEM	PART NUMBER	DESCRIPTION	QTY
1	700-48	THROTTLE HANDLE CAP SCREW	2
2	7WS-08B	THROTTLE HANDLE LOCK WASHER	2
3	69A-E12	THROTTLE HANDLE ASSEMBLY	1
4	CSH-135-002	"Z" FRAME ASSEMBLY	1
5	7SACD08-25B	FRAME CAP SCREW	2
6	700-54	FRAME LOCK WASHER	2
7	7SFDD08-60D	HANDLE CAP SCREW	2
8	7WF-08B	HANDLE WASHER	3
9	CSH-135-003	HANDLE	1
10	CSH-135-007	HANDLE MOUNT CAP SCREW	1
11	0210714	HANDLE MOUNT	1
12	CSH100-2	Z-FRAME MOTOR SEAL	1
13	460-1A-GBX	AIR MOTOR GEARBOX ASSEMBLY	1
14	CSH160-GUAR	18" GUARD (FOR CSH-160)	1
15	0210715	GUARD SPACER	1
16	MC2375	GUARD SNAP RING	1
17	0265042	INNER FLANGE	1
18	0252257	OUTER FLANGE	1
19	0252256	FLANGE NUT	1
20	1100-200	WRENCH	2
21,22	WH-5	OILER, HOSE ASSEMBLY	1
23	CSH135-GUAR	14" GUARD (FOR CSH-135)	1

CS Unitec, Inc.

22 Harbor Ave., Norwalk CT 06850 USA
 4330 Center St., Deer Park, TX 77536 USA

Phone (800) 700-5919 or (203) 853-9522 • Fax (203) 853-9921
 www.csunitec.com • e-mail: info@csunitec.com



THROTTLE HANDLE ASSEMBLY

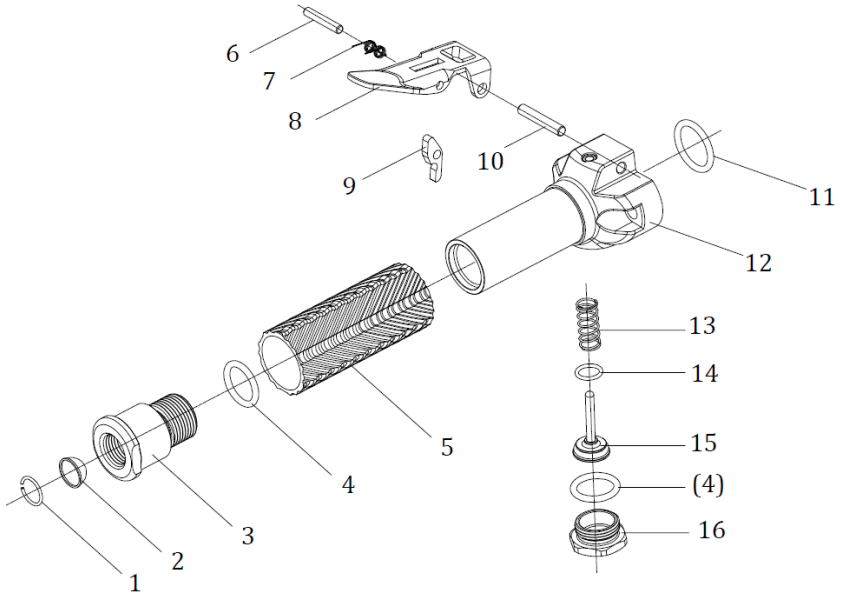

CS Unitec, Inc.

22 Harbor Ave., Norwalk CT 06850 USA
4330 Center St., Deer Park, TX 77536 USA

Phone (800) 700-5919 or (203) 853-9522 • Fax (203) 853-9921
www.csunitec.com • e-mail: info@csunitec.com



THROTTLE HANDLE BILL OF MATERIALS			
ITEM	PART NUMBER	DESCRIPTION	QTY
1	84-E12N	LEVER RETAINING RING	1
2	95-1700	INLET SCREEN	1
3	45-E12	INLET BUSHING	1
4	93-118	O-RING	2
5	85-E12ATP	HANDLE GRIP	1
6	2187-1125	SAFTEY PAWL ROLL PIN	1
7	97-E12	SPRING	1
8	31-E12	THROTTLE LEVER	1
9	82A-E12	SAFETY PAWL	1
10	2250-1500	THROTTLE LEVER ROLL PIN	1
11	700-30	THROTTLE BODY O-RING	1
12	69-E12	THROTTLE BODY	1
13	26-2WA	VALVE SPRING	1
14	93-206	VALVE O-RING	1
15	91-E12	THROTTLE VALVE	1
16	30-E12	THROTTLE VALVE CAP	1

CS Unitec, Inc.

22 Harbor Ave., Norwalk CT 06850 USA
4330 Center St., Deer Park, TX 77536 USA

Phone (800) 700-5919 or (203) 853-9522 • Fax (203) 853-9921
www.csunitec.com • e-mail: info@csunitec.com

UNITEC

AIR MOTOR GEARBOX ASSEMBLY

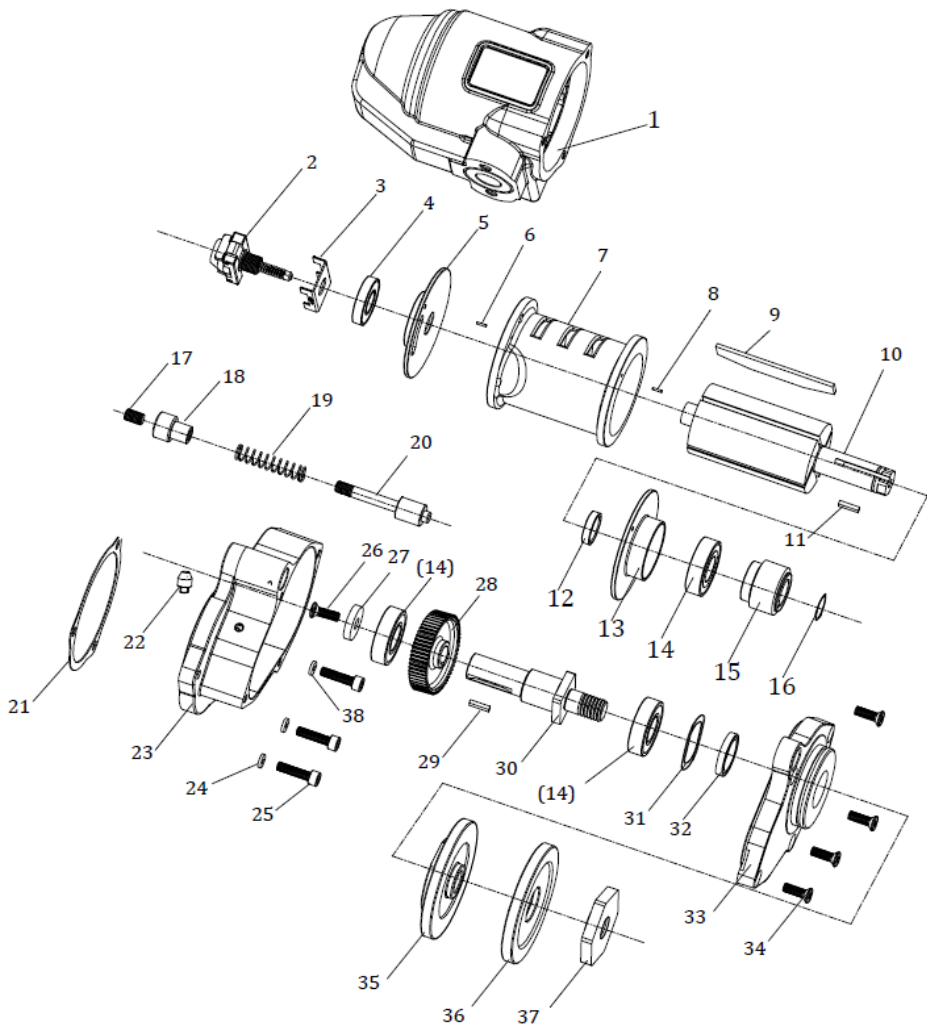

CS Unitec, Inc.

22 Harbor Ave., Norwalk CT 06850 USA
4330 Center St., Deer Park, TX 77536 USA

Phone (800) 700-5919 or (203) 853-9522 • Fax (203) 853-9921
www.csunitec.com • e-mail: info@csunitec.com



AIR MOTOR GEARBOX BILL OF MATERIALS			
ITEM	PART NUMBER	DESCRIPTION	QTY
1	460-1M	MOTOR HOUSING	1
2	92340	GOVERNOR ASSEMBLY	1
3	600-48 /0260048	GOVERNOR RETAINER	1
4	700-9	REAR BEARING	1
5	360-3	REAR END PLATE	1
6	360-15	REAR ALIGNMENT PIN	1
7	460-5M	CYLINDER LINER	1
8	360-16	FRONT SPRING PIN	1
9	460-6	ROTOR BLADE	4
10	460-2M-SAW	ROTOR, SAW	1
11	19502	ROTOR KEY	1
12	340-4	FRONT BEARING SPACER	1
13	360-10	FRONT END PLATE	1
14	700-7	FRONT BEARING	3
15	19503	SMALL INPUT GEAR	1
16	0259261	BEARING RETAINING CLIP	1
17	0259110M	SET SCREW	1
18	0266119M	LOCK PIN KNOB	1
19	0266125	LOCK PIN SPRING	1
20	0266120M	LOCK PIN SHAFT	1
21	360-1	REAR GASKET	1
22	CSH-135-008	GREASE FITTING	1
23	19468	GEAR BOX HOUSING	1
24	270046	LOCK WASHER	2
25	270047	CAP SCREW	3
26	7SECY08-15B	HOUSING FLAT HD HEX CAP SCREW	1
27	19509	CONE WASHER	1
28	19508	LARGE OUTPUT GEAR	1
29	19507	OUTPUT SHAFT KEY	1
30	19505	OUTPUT SHAFT	1
31	0266124	WAVE SPRING WASHER	1
32	0266123	FRONT SEAL	1
33	19487	GEAR BOX COVER	1
34	7SECY06-25B	COVER FLAT HD HEX CAP SCREW	4
35	0265042	INNER FLANGE	1
36	0252257	OUTER FLANGE	1
37	0252256	FLANGE NUT	1
38	7WS-06B	HOUSING LOCK WASHER	1

CS Unitec, Inc.

22 Harbor Ave., Norwalk CT 06850 USA
 4330 Center St., Deer Park, TX 77536 USA

Phone (800) 700-5919 or (203) 853-9522 • Fax (203) 853-9921
 www.csunitec.com • e-mail: info@csunitec.com



PRE-OPERATING INSTRUCTIONS

Check air supply for correct pressure (90 PSI min.) and sufficient flow (85 CFM min.). Daily, blow out air line to dislodge any debris, moisture or foreign matter from the air line and the compressor. **WARNING!** Use extreme caution when blowing out pressurized air lines and or air hoses. Expelled particles can cause severe injury. Connect water hose for wet-cutting applications, or vacuum hose for dry-cutting applications. Connect air supply hose to saw. Check for leaks.

OPERATING INSTRUCTIONS

Under no circumstances should this saw be operated by personnel who have not been trained in the operation of saw cutting.

Start with the saw positioned above the surface being cut. Squeeze the throttle. When the saw has attained full speed, slowly engage it into the cut. Because the saw cuts in a clockwise direction, it will pull itself into the cut. A small amount of resistance should be applied when first entering the cut. **Do not under any circumstance** force the blade into the cut, as forcing could bend or break the blade. When finishing the cut, slowly raise the saw until the blade is clear of the cut. Release the trigger and let the motor come to a complete stop.

CS Unitec, Inc.

22 Harbor Ave., Norwalk CT 06850 USA
4330 Center St., Deer Park, TX 77536 USA

Phone (800) 700-5919 or (203) 853-9522 • Fax (203) 853-9921
www.csunitec.com • e-mail: info@csunitec.com



WARNINGS!!!

- Always turn off the air supply and disconnect the air supply hose before installing, removing, or adjusting any accessory on this tool — especially the cutting blade — or before performing any maintenance on this tool. Failure to do so could result in serious injury or death!
- Pneumatic tools can vibrate during use. Repetitive motions, uncomfortable positions and vibrations can cause injury to hands, fingers, or wrists. **STOP** using any tool if discomfort, a tingling feeling, or pain occurs. Seek your supervisor's advice before resuming use.
- **Projectile Hazard** - Always wear safety glasses to prevent eye injury or loss of sight when operating power tools. ***The most important safety device for this tool or any power tool is YOU!*** Your care and good judgment are the best protection against injury.
- Hearing loss can result from prolonged exposure to excessive sound levels. **ALWAYS** use approved hearing protection.
- Dust mask should be worn when using this saw in dry-cutting applications.
- Wear safety shoes during equipment use. DO NOT wear loose clothing which could get caught in equipment.

CS Unitec, Inc.

22 Harbor Ave., Norwalk CT 06850 USA
4330 Center St., Deer Park, TX 77536 USA

Phone (800) 700-5919 or (203) 853-9522 • Fax (203) 853-9921
www.csunitec.com • e-mail: info@csunitec.com



CS Unitec Hand-Held Pneumatic Concrete Saw

Congratulations on your purchase. We consider the CS Unitec Hand-Held Pneumatic Concrete Saw to be among the finest concrete saws in the world. It is engineered to withstand the construction environment and will last many years with the proper care and maintenance.

The heart of the pneumatic hand-held saw is a newly developed pneumatic motor coupled with a heavy-duty gear drive. Our motor runs at a higher speed than most conventional saws and attains its amazing horsepower from this optimum speed. The gear drive then reduces the speed attaining the maximum torque.

FIRST AND FOREMOST:

The use of blades, oil, and replacement parts other than those supplied by CS Unitec may compromise your saw's performance, operator safety, and also lead to higher-than-normal maintenance and repair requirements.

ADDITIONALLY:

1. Pneumatic tool lubrication is critical to achieving the maximum performance and life from your pneumatic tool. We strongly suggest lubrication through the air inlet. When using an in-line oiler, install it as close to the motor as possible. One drop of oil per minute is adequate lubrication for most pneumatic motors.
2. It is also recommended that, when the saw is going to be shut down at the end of the day, the air line be shut off and the saw disconnected. Pour approximately 1/2 oz. of CS Unitec Air Tool Lubricant into the line, then reconnect the line to the saw and give the throttle about a 2-second burst. This procedure will coat the internal parts of the motor displacing any moisture and will prevent any rust or corrosion.
3. All CS Unitec pneumatic tools should be operated and maintained in accordance with American National

CS Unitec, Inc.

22 Harbor Ave., Norwalk CT 06850 USA
4330 Center St., Deer Park, TX 77536 USA

Phone (800) 700-5919 or (203) 853-9522 • Fax (203) 853-9921
www.csunitec.com • e-mail: info@csunitec.com



Standards Institute Safety Code for Portable Air Tools (ANSI B186.1) and any other applicable safety codes and regulations. B186.1 information is available from the National Standards Institute, Inc., 11 West 42nd Street, New York, NY 10036.

CS Unitec, Inc.

22 Harbor Ave., Norwalk CT 06850 USA
4330 Center St., Deer Park, TX 77536 USA

Phone (800) 700-5919 or (203) 853-9522 • Fax (203) 853-9921
www.csunitec.com • e-mail: info@csunitec.com



WARRANTY

The manufacturer of this product warrants this product to be free from defects in materials and workmanship for a period of six (6) months from the date of original purchase.

THERE ARE NO OTHER WARRANTIES WHICH EXTEND BEYOND THE ABOVE. ALL OTHER WARRANTIES, EITHER EXPRESS OR IMPLIED, ARE EXCLUDED, INCLUDING ANY IMPLIED WARRANTY OF MERCHANTABILITY, FITNESS, OR FITNESS FOR A PARTICULAR PURPOSE.

IN NO EVENT SHALL THE MANUFACTURER BE LIABLE TO THE PURCHASER FOR CONSEQUENTIAL DAMAGES OR DAMAGES FOR PERSONAL INJURY. THE PURCHASER HEREBY ASSUMES ALL RISKS INVOLVED IN THE USE OF THIS PRODUCT.

Any part of the product that is found by the manufacturer to be defective during the warranty period above will be replaced or repaired, at the manufacturer's sole discretion, without charge for such repair or replacement.

SUBJECTING THE PRODUCT TO ANY OF THE CONDITIONS LISTED BELOW WILL VOID THIS WARRANTY:

- A. Misuse, negligence, or accident.
- B. Failure to operate or maintain the product in accordance with the Operating and Safety Manual furnished by the manufacturer.
- C. Alterations or modifications without WRITTEN permission from the manufacturer.
- D. Use of accessories which are not officially approved by the manufacturer in writing.

The manufacturer reserves the right to change or improve the design of the product without assuming obligation to update any products previously manufactured.

CS Unitec, Inc.
22 Harbor Ave., Norwalk CT 06850 USA
4330 Center St., Deer Park, TX 77536 USA

Phone (800) 700-5919 or (203) 853-9522 • Fax (203) 853-9921
www.csunitec.com • e-mail: info@csunitec.com



OPERATIONAL AND SAFETY INSTRUCTIONS:

**BE SURE TO READ ALL INSTRUCTIONS BEFORE ASSEMBLING
AND OPERATING THIS EQUIPMENT.**

- All CS Unitec pneumatic saws are designed to be operated @ 90 PSI min. (6.2 bar) air pressure 100 psi maximum, 85 CFM min., with a minimum 1/2" (13 mm) I.D. air hose. Using higher pressure to attain more horsepower will drastically shorten tool life.
- After every 40 hours of operation, or as experience indicates, inject 1 to 2 cc's (2-3 pump strokes) of a quality gear grease into the saw's zerk fittings.
- Check the area to be cut; be sure it is free of all loose debris, and be sure no one is standing in the cut line.
- Use only CS Unitec-approved diamond blades that have been rated for this saw's R.P.M. Inspect all blades for damage before use. **Do not under any circumstance** use a bent or warped blade, or a blade with a missing segment, as an out-of-balance condition could result in the blade coming apart.
- Always check arbor bearing for end play.
- Check that the guard is secure and undamaged.
- Check to see that all nuts and bolts are tight.
- Never cut material for which the blade is not designed.
- Do not start, run or operate the equipment near combustible materials.

CS Unitec, Inc.

22 Harbor Ave., Norwalk CT 06850 USA
4330 Center St., Deer Park, TX 77536 USA

Phone (800) 700-5919 or (203) 853-9522 • Fax (203) 853-9921
www.csunitec.com • e-mail: info@csunitec.com



ASSEMBLY INSTRUCTIONS

1. Install blade. This saw rotates in a clockwise direction when viewed from the right side of the saw. Be careful that the arrow on the blade goes in the same (clockwise) direction. Place blade on the hub of the inner flange and then secure the outer flange and 5/8"-11 left-hand nut. Use the two wrenches supplied to tighten the blade, and spin the blade by hand to see that it is running true. Check that all nuts and bolts are tight.
2. Connect the air supply
3. Connect the clear water hose from the handle assembly to the water spray fitting on top of the guard.

Saws returned to CS Unitec for warranty consideration must be shipped prepaid, along with proof of date of purchase, a brief description of the problem, and a CS Unitec Return Goods Authorization (RGA) number issued by CS Unitec's Customer Service Department.

CS Unitec, Inc.
22 Harbor Ave., Norwalk CT 06850 USA
4330 Center St., Deer Park, TX 77536 USA

Phone (800) 700-5919 or (203) 853-9522 • Fax (203) 853-9921
www.csunitec.com • e-mail: info@csunitec.com



Operation Manual & Parts List

Model CSH 160
18" Hand-Held Pneumatic Concrete Saw
and
Model CSH 135
14" Hand-Held Pneumatic Concrete Saw



CS Unitec, Inc.

22 Harbor Ave., Norwalk CT 06850 USA
4330 Center St., Deer Park, TX 77536 USA

Phone (800) 700-5919 or (203) 853-9522 • Fax (203) 853-9921
www.csunitec.com • e-mail: info@csunitec.com