



Owner's Manual and Operating Instructions
Model CSR-150
20" Walk-Behind Pneumatic Concrete Saw



CS Unitec, Inc.

Printed in U.S.A. Copyright CS Unitec, Inc. 2006



Owner's Manual and Operating Instructions
Model CSR-150
20" Walk-Behind Pneumatic Concrete Saw



CS Unitec, Inc.

Printed in U.S.A. Copyright CS Unitec, Inc. 2006

**CS Unitec Model CSR-150
20" Walk-Behind Pneumatic Concrete Saw**

Congratulations on your purchase. We consider the CS Unitec Model CSR-150 20" pneumatic concrete saw to be among the finest concrete saws in the world. It has been engineered to withstand the construction environment and will last many years with the proper care and maintenance.

The heart of the CSR-150 is a newly developed pneumatic motor coupled with a heavy-duty gear drive. Our motor runs at a higher speed than most conventional saws and attains its amazing horsepower from this optimum speed. The gear drive then reduces the speed attaining the maximum horsepower.

FIRST AND FOREMOST:

The use of blades, oil, and replacement parts other than those supplied by CS Unitec may compromise your saw's performance, operator safety, and also lead to higher-than-normal maintenance and repair requirements.

ADDITIONALLY:

1. Pneumatic tool lubrication is critical to achieving the maximum performance and life from your pneumatic tool. We strongly suggest lubrication through the air inlet. When using an in-line oiler, install it as close to the motor as possible. One drop of oil per minute is adequate lubrication for most pneumatic motors.
2. It is also recommended that, when the saw is going to be shut down at the end of the day, the air line be shut off and the saw disconnected. Pour approximately 1/2 oz. of CS Unitec Air Tool Lubricant into the line, then reconnect the line to the saw and give the throttle about a 2-second burst. This procedure will coat the internal parts of the motor displacing any moisture and will prevent any rust or corrosion.
3. All CS Unitec pneumatic tools should be operated and maintained in accordance with American National Standards Institute Safety Code for Portable Air Tools (ANSI B186.1) and any other applicable safety codes and regulations. B186.1 information is available from the National Standards Institute, Inc., 11 West 42nd Street, New York, NY 10036.

CS Unitec, Inc.

22 Harbor Ave., Norwalk CT 06850

Phone (800) 700-5919 or (203) 853-9522 ♦ Fax (203) 853-9921

Website: <http://www.csunitec.com> ♦ e-mail: info@csunitec.com

**CS Unitec Model CSR-150
20" Walk-Behind Pneumatic Concrete Saw**

Congratulations on your purchase. We consider the CS Unitec Model CSR-150 20" pneumatic concrete saw to be among the finest concrete saws in the world. It has been engineered to withstand the construction environment and will last many years with the proper care and maintenance.

The heart of the CSR-150 is a newly developed pneumatic motor coupled with a heavy-duty gear drive. Our motor runs at a higher speed than most conventional saws and attains its amazing horsepower from this optimum speed. The gear drive then reduces the speed attaining the maximum horsepower.

FIRST AND FOREMOST:

The use of blades, oil, and replacement parts other than those supplied by CS Unitec may compromise your saw's performance, operator safety, and also lead to higher-than-normal maintenance and repair requirements.

ADDITIONALLY:

1. Pneumatic tool lubrication is critical to achieving the maximum performance and life from your pneumatic tool. We strongly suggest lubrication through the air inlet. When using an in-line oiler, install it as close to the motor as possible. One drop of oil per minute is adequate lubrication for most pneumatic motors.
2. It is also recommended that, when the saw is going to be shut down at the end of the day, the air line be shut off and the saw disconnected. Pour approximately 1/2 oz. of CS Unitec Air Tool Lubricant into the line, then reconnect the line to the saw and give the throttle about a 2-second burst. This procedure will coat the internal parts of the motor displacing any moisture and will prevent any rust or corrosion.
3. All CS Unitec pneumatic tools should be operated and maintained in accordance with American National Standards Institute Safety Code for Portable Air Tools (ANSI B186.1) and any other applicable safety codes and regulations. B186.1 information is available from the National Standards Institute, Inc., 11 West 42nd Street, New York, NY 10036.

CS Unitec, Inc.

22 Harbor Ave., Norwalk CT 06850

Phone (800) 700-5919 or (203) 853-9522 ♦ Fax (203) 853-9921

Website: <http://www.csunitec.com> ♦ e-mail: info@csunitec.com

OPERATIONAL AND SAFETY INSTRUCTIONS:

BE SURE TO READ ALL INSTRUCTIONS BEFORE ASSEMBLING AND OPERATING THIS EQUIPMENT.

- * All CS Unitec pneumatic saws are designed to be operated @ 90 P.S.I. min. (6.2 bar) air pressure, 85 CFM min., with a minimum 1/2" (13 mm) I.D. air hose. Using higher pressure to attain more horsepower will drastically shorten tool life.
- * The Saw motor is factory pre-set at 2900 RPM. Be sure your blade will operate at that speed.
- * After every 40 hours of operation, or as experience indicates, inject 1 to 2 cc's (2-3 pump strokes) of a quality gear grease into the saw's zerk fittings.

W A R N I N G S !!

- * Always turn off the air supply and disconnect the air supply hose before installing, removing, or adjusting any accessory on this tool — especially the cutting blade — or before performing any maintenance on this tool. Failure to do so could result in serious injury or death!
- * Pneumatic tools can vibrate during use. Repetitive motions, uncomfortable positions and vibrations can cause injury to hands, fingers, or wrists. **STOP** using any tool if discomfort, a tingling feeling, or pain occurs. Seek your supervisor's advice before resuming use.
- * **Projectile Hazard** - Always wear safety glasses to prevent eye injury or loss of sight when operating power tools. ***The most important safety device for this tool or any power tool is YOU!*** Your care and good judgment are the best protection against injury.
- * Hearing loss can result from prolonged exposure to excessive sound levels. **ALWAYS** use approved hearing protection.
- * Dust mask should be worn when using this saw in dry-cutting applications.
- * Wear safety shoes during equipment use. **DO NOT** wear loose clothing which could get caught in equipment.

OPERATIONAL AND SAFETY INSTRUCTIONS:

BE SURE TO READ ALL INSTRUCTIONS BEFORE ASSEMBLING AND OPERATING THIS EQUIPMENT.

- * All CS Unitec pneumatic saws are designed to be operated @ 90 P.S.I. min. (6.2 bar) air pressure, 85 CFM min., with a minimum 1/2" (13 mm) I.D. air hose. Using higher pressure to attain more horsepower will drastically shorten tool life.
- * The Saw motor is factory pre-set at 2900 RPM. Be sure your blade will operate at that speed.
- * After every 40 hours of operation, or as experience indicates, inject 1 to 2 cc's (2-3 pump strokes) of a quality gear grease into the saw's zerk fittings.

W A R N I N G S !!

- * Always turn off the air supply and disconnect the air supply hose before installing, removing, or adjusting any accessory on this tool — especially the cutting blade — or before performing any maintenance on this tool. Failure to do so could result in serious injury or death!
- * Pneumatic tools can vibrate during use. Repetitive motions, uncomfortable positions and vibrations can cause injury to hands, fingers, or wrists. **STOP** using any tool if discomfort, a tingling feeling, or pain occurs. Seek your supervisor's advice before resuming use.
- * **Projectile Hazard** - Always wear safety glasses to prevent eye injury or loss of sight when operating power tools. ***The most important safety device for this tool or any power tool is YOU!*** Your care and good judgment are the best protection against injury.
- * Hearing loss can result from prolonged exposure to excessive sound levels. **ALWAYS** use approved hearing protection.
- * Dust mask should be worn when using this saw in dry-cutting applications.
- * Wear safety shoes during equipment use. **DO NOT** wear loose clothing which could get caught in equipment.

OPERATIONAL AND SAFETY INSTRUCTIONS - continued

- ◆ Check the area to be cut; be sure it is free of all loose debris, and be sure no-one is standing in the cut line.
- ◆ Use only CS Unitec-approved diamond blades that have been rated for this saw's r.p.m. Inspect all blades for damage before use. **Do not under any circumstance** use a bent or warped blade, or a blade with a missing segment, as an out-of-balance condition could result in the blade coming apart.
- ◆ Always check arbor bearing for end play.
- ◆ Check that the guard is secure and undamaged.
- ◆ Check to see that all nuts and bolts are tight.
- ◆ Never cut material for which the blade is not designed.
- ◆ Do not start, run or operate the equipment near combustible materials.

ASSEMBLY INSTRUCTIONS

1. Slip handle assembly over the two 3/4" handle pins. Tighten the two 3/8" set bolts to secure the handle.
2. Connect height control jack assembly on the handle to the top of the motor mount with the 3/8"x 3/4" bolt supplied. Raise the jack to full up position to install blade.
3. Connect the air hose from the center of the handle to the in-line oiler on the motor. Fill the oiler with CS Unitec Air Tool Lubricant.
4. Connect the clear water hose from the handle assembly to the water spray head on top of the guard.
5. Install blade. This saw rotates in a clockwise direction when viewed from the right side of the saw. Be careful that the arrow on the blade goes in the same (clockwise) direction. Place blade on the hub of the inner flange and then secure the outer flange and 5/8"-11 left-hand nut. Use the two wrenches supplied to tighten the blade, and spin the blade by hand to see that it is running true. Check that all nuts and bolts are tight.

OPERATIONAL AND SAFETY INSTRUCTIONS - continued

- ◆ Check the area to be cut; be sure it is free of all loose debris, and be sure no-one is standing in the cut line.
- ◆ Use only CS Unitec-approved diamond blades that have been rated for this saw's r.p.m. Inspect all blades for damage before use. **Do not under any circumstance** use a bent or warped blade, or a blade with a missing segment, as an out-of-balance condition could result in the blade coming apart.
- ◆ Always check arbor bearing for end play.
- ◆ Check that the guard is secure and undamaged.
- ◆ Check to see that all nuts and bolts are tight.
- ◆ Never cut material for which the blade is not designed.
- ◆ Do not start, run or operate the equipment near combustible materials.

ASSEMBLY INSTRUCTIONS

1. Slip handle assembly over the two 3/4" handle pins. Tighten the two 3/8" set bolts to secure the handle.
2. Connect height control jack assembly on the handle to the top of the motor mount with the 3/8"x 3/4" bolt supplied. Raise the jack to full up position to install blade.
3. Connect the air hose from the center of the handle to the in-line oiler on the motor. Fill the oiler with CS Unitec Air Tool Lubricant.
4. Connect the clear water hose from the handle assembly to the water spray head on top of the guard.
5. Install blade. This saw rotates in a clockwise direction when viewed from the right side of the saw. Be careful that the arrow on the blade goes in the same (clockwise) direction. Place blade on the hub of the inner flange and then secure the outer flange and 5/8"-11 left-hand nut. Use the two wrenches supplied to tighten the blade, and spin the blade by hand to see that it is running true. Check that all nuts and bolts are tight.

ASSEMBLY DIAGRA

M

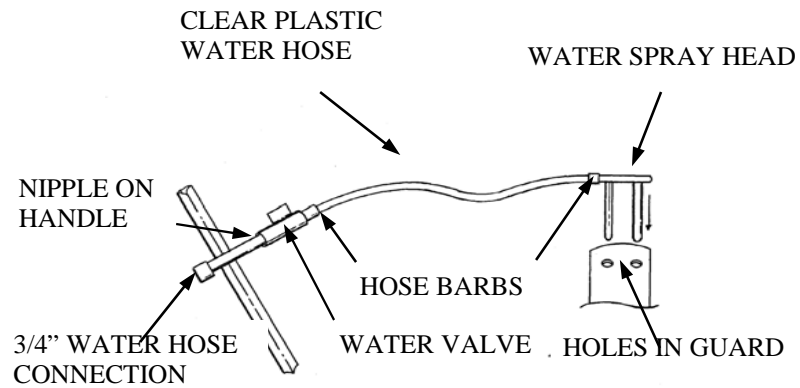
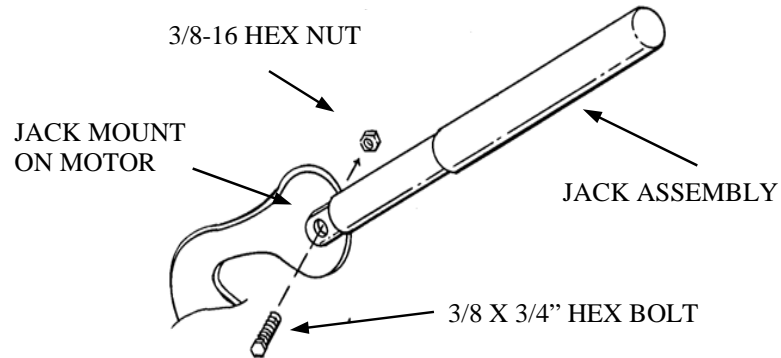
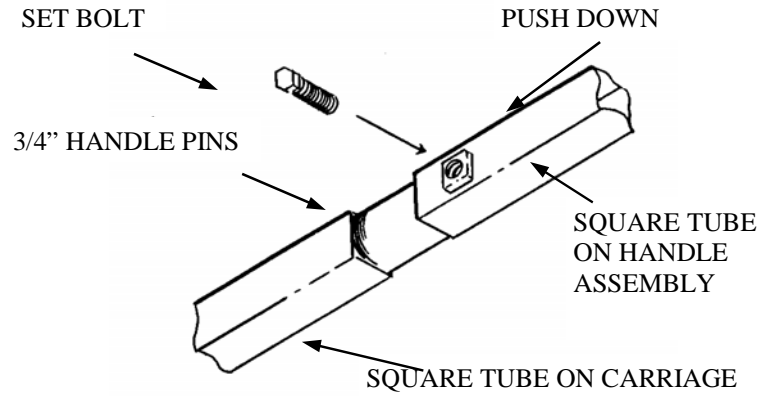

ASSEMBLY DIAGRAM

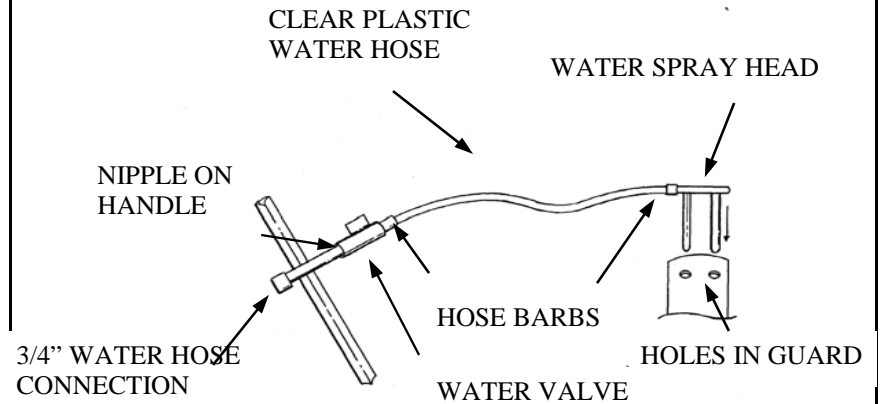
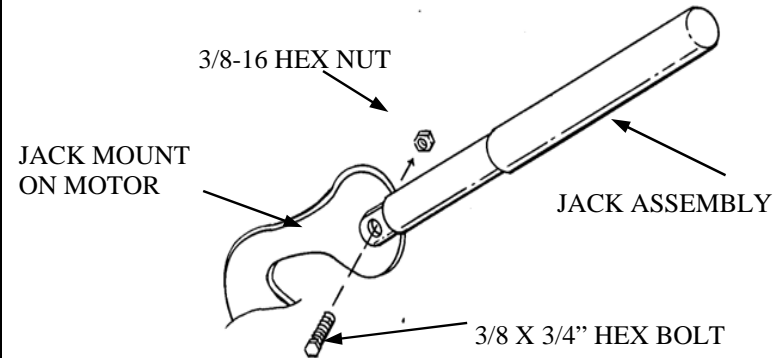
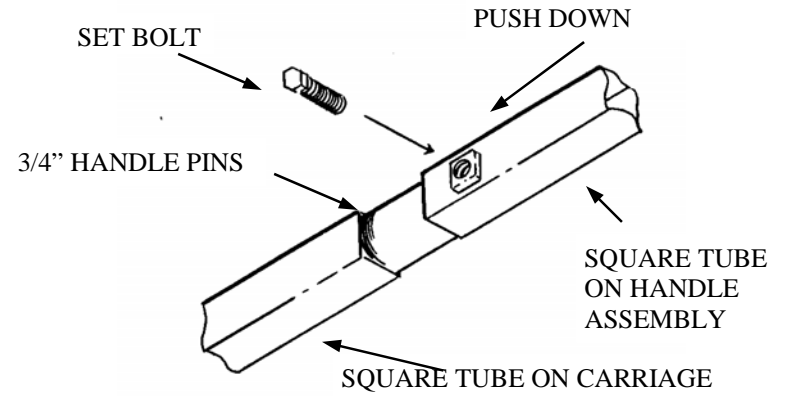

PRE-OPERATING INSTRUCTIONS

Check air supply for correct pressure (90 PSI min.) and sufficient flow (85 CFM min.). Daily, blow out air line to dislodge any debris, moisture or foreign matter from the air line and the compressor. **WARNING!** Use extreme caution when blowing out pressurized air lines and or air hoses. Expelled particles can cause severe injury. Connect water hose for wet-cutting applications, or vacuum hose for dry-cutting applications. Connect air supply hose to saw. Check for leaks.

OPERATING INSTRUCTIONS

Under no circumstances should this saw be operated by personnel who have not been trained in the operation of saw cutting.

Make sure the blade is in the raised position and not in contact with the surface being cut. Squeeze the throttle. When the saw has attained full speed, slowly engage it into the cut. Because the saw cuts in a clockwise direction, it will pull itself into the cut. A small amount of resistance should be applied when first entering the cut. **Do not under any circumstance** force the blade into the cut, as forcing could bend or break the blade. When finishing the cut, slowly raise the jack until the blade is clear of the cut. Release the trigger and let the motor come to a complete stop.

Saws returned to CS Unitec for warranty consideration must be shipped prepaid, along with proof of date of purchase, a brief description of the problem, and a CS Unitec Return Goods Authorization (RGA) number issued by CS Unitec's Customer Service Department.

PRE-OPERATING INSTRUCTIONS

Check air supply for correct pressure (90 PSI min.) and sufficient flow (85 CFM min.). Daily, blow out air line to dislodge any debris, moisture or foreign matter from the air line and the compressor. **WARNING!** Use extreme caution when blowing out pressurized air lines and or air hoses. Expelled particles can cause severe injury. Connect water hose for wet-cutting applications, or vacuum hose for dry-cutting applications. Connect air supply hose to saw. Check for leaks.

OPERATING INSTRUCTIONS

Under no circumstances should this saw be operated by personnel who have not been trained in the operation of saw cutting.

Make sure the blade is in the raised position and not in contact with the surface being cut. Squeeze the throttle. When the saw has attained full speed, slowly engage it into the cut. Because the saw cuts in a clockwise direction, it will pull itself into the cut. A small amount of resistance should be applied when first entering the cut. **Do not under any circumstance** force the blade into the cut, as forcing could bend or break the blade. When finishing the cut, slowly raise the jack until the blade is clear of the cut. Release the trigger and let the motor come to a complete stop.

Saws returned to CS Unitec for warranty consideration must be shipped prepaid, along with proof of date of purchase, a brief description of the problem, and a CS Unitec Return Goods Authorization (RGA) number issued by CS Unitec's Customer Service Department.

WARRANTY

The manufacturer of this product warrants this product to be free from defects in materials and workmanship for a period of one year from the date of original purchase.

THERE ARE NO OTHER WARRANTIES WHICH EXTEND BEYOND THE ABOVE. ALL OTHER WARRANTIES, EITHER EXPRESS OR IMPLIED, ARE EXCLUDED, INCLUDING ANY IMPLIED WARRANTY OF MERCHANTABILITY, FITNESS, OR FITNESS FOR A PARTICULAR PURPOSE.

IN NO EVENT SHALL THE MANUFACTURER BE LIABLE TO THE PURCHASER FOR CONSEQUENTIAL DAMAGES OR DAMAGES FOR PERSONAL INJURY. THE PURCHASER HEREBY ASSUMES ALL RISKS INVOLVED IN THE USE OF THIS PRODUCT.

Any part of the product that is found by the manufacturer to be defective during the warranty period above will be replaced or repaired, at the manufacturer's sole discretion, without charge for such repair or replacement.

SUBJECTING THE PRODUCT TO ANY OF THE CONDITIONS LISTED BELOW WILL VOID THIS WARRANTY:

- A. Misuse, negligence, or accident.
- B. Failure to operate or maintain the product in accordance with the Operating and Safety Manual furnished by the manufacturer.
- C. Alterations or modifications without WRITTEN permission from the manufacturer.
- D. Use of accessories which are not officially approved by the manufacturer in writing.

The manufacturer reserves the right to change or improve the design of the product without assuming obligation to update any products previously manufactured.

WARRANTY

The manufacturer of this product warrants this product to be free from defects in materials and workmanship for a period of one year from the date of original purchase.

THERE ARE NO OTHER WARRANTIES WHICH EXTEND BEYOND THE ABOVE. ALL OTHER WARRANTIES, EITHER EXPRESS OR IMPLIED, ARE EXCLUDED, INCLUDING ANY IMPLIED WARRANTY OF MERCHANTABILITY, FITNESS, OR FITNESS FOR A PARTICULAR PURPOSE.

IN NO EVENT SHALL THE MANUFACTURER BE LIABLE TO THE PURCHASER FOR CONSEQUENTIAL DAMAGES OR DAMAGES FOR PERSONAL INJURY. THE PURCHASER HEREBY ASSUMES ALL RISKS INVOLVED IN THE USE OF THIS PRODUCT.

Any part of the product that is found by the manufacturer to be defective during the warranty period above will be replaced or repaired, at the manufacturer's sole discretion, without charge for such repair or replacement.

SUBJECTING THE PRODUCT TO ANY OF THE CONDITIONS LISTED BELOW WILL VOID THIS WARRANTY:

- A. Misuse, negligence, or accident.
- B. Failure to operate or maintain the product in accordance with the Operating and Safety Manual furnished by the manufacturer.
- C. Alterations or modifications without WRITTEN permission from the manufacturer.
- D. Use of accessories which are not officially approved by the manufacturer in writing.

The manufacturer reserves the right to change or improve the design of the product without assuming obligation to update any products previously manufactured.



CS Unitec
CSR-150 Parts List w/ Part Numbers

1. Saw Body Assembly CSR150-001
2. 20" Guard Assembly CSR150-002
3. Handle Assembly CSR150-003
4. Motor w/ Gear Box Asbly. CSR150-004
5. Stub Handle CSR150-005
6. Jack Assembly CSR150-006
7. Wrenches (2 req.) CSR150-007
8. 6" x 2" Wheel (3 req.) CSR150-008
9. Inner Blade Flange CSR150-009
10. Outer Blade Flange CSR150-010
11. Motor Retainer Snap Ring CSR150-011
12. Clear Water Hose CSR150-012
13. Wheel Flange Nut CSR150-013
14. Air Supply Hose CSR150-014
15. Throttle CSR150-015
16. Oiler Assembly CSR150-016
17. Jack Axle CSR150-017

-- continued on next page --



CS Unitec
CSR-150 Parts List w/ Part Numbers

1. Saw Body Assembly CSR150-001
2. 20" Guard Assembly CSR150-002
3. Handle Assembly CSR150-003
4. Motor w/ Gear Box Asbly. CSR150-004
5. Stub Handle CSR150-005
6. Jack Assembly CSR150-006
7. Wrenches (2 req.) CSR150-007
8. 6" x 2" Wheel (3 req.) CSR150-008
9. Inner Blade Flange CSR150-009
10. Outer Blade Flange CSR150-010
11. Motor Retainer Snap Ring CSR150-011
12. Clear Water Hose CSR150-012
13. Wheel Flange Nut CSR150-013
14. Air Supply Hose CSR150-014
15. Throttle CSR150-015
16. Oiler Assembly CSR150-016
17. Jack Axle CSR150-017

-- continued on next page --

CS Unitec
CSR-150 Small Parts List w/ Part Numbers
continued from page 7

- | | | |
|-----|----------------------------------|------------|
| 18. | 3/8" NPT Ball Valve | CSR150-018 |
| 19. | Spray Bar Assembly | CSR150-019 |
| 20. | Water Hose Connection Fitting | CSR150-020 |
| 21. | Water Hose Fittings (2 req.) | CSR150-021 |
| 22. | Guide Wheel | CSR150-022 |
| 23. | 3/4" Washers (6 req.) | CSR150-023 |
| 24. | 3/8" Washers (6 req.) | CSR150-024 |
| 25. | 3/8" x 1" bolts (2 req.) | CSR150-025 |
| 26. | 1/8" Cotter Pin (3 req.) | CSR150-026 |
| 27. | Push Caps for Jack Axle (2 req.) | CSR150-027 |
| 28. | 3/8"x 1-1/2" Bolt | CSR150-028 |
| 29. | 3/8" Nuts (3 required) | CSR150-029 |



CS Unitec
CSR-150 Small Parts List w/ Part Numbers
continued from page 7

- | | | |
|-----|----------------------------------|------------|
| 18. | 3/8" NPT Ball Valve | CSR150-018 |
| 19. | Spray Bar Assembly | CSR150-019 |
| 20. | Water Hose Connection Fitting | CSR150-020 |
| 21. | Water Hose Fittings (2 req.) | CSR150-021 |
| 22. | Guide Wheel | CSR150-022 |
| 23. | 3/4" Washers (6 req.) | CSR150-023 |
| 24. | 3/8" Washers (6 req.) | CSR150-024 |
| 25. | 3/8" x 1" bolts (2 req.) | CSR150-025 |
| 26. | 1/8" Cotter Pin (3 req.) | CSR150-026 |
| 27. | Push Caps for Jack Axle (2 req.) | CSR150-027 |
| 28. | 3/8"x 1-1/2" Bolt | CSR150-028 |
| 29. | 3/8" Nuts (3 required) | CSR150-029 |



CS Unitec, Inc.

22 Harbor Ave., Norwalk CT 06850

Phone (800) 700-5919 or (203) 853-9522 ♦ Fax (203) 853-9921

Website: <http://www.csunitec.com> ♦ e-mail: info@csunitec.com

CS Unitec, Inc.

22 Harbor Ave., Norwalk CT 06850

Phone (800) 700-5919 or (203) 853-9522 ♦ Fax (203) 853-9921

Website: <http://www.csunitec.com> ♦ e-mail: info@csunitec.com