

**CS UNITEC**

**Diamond Chain Repair Manual**  
**For**  
**Pneumatic Concrete Chain Saws**

**CS UNITEC, Inc.**

22 Harbor Avenue, Norwalk, CT 06850

Tel: (203) 853-9522, Toll Free: (800) 700-5919, Fax: (203) 853-9921

Website: [www.csunitec.com](http://www.csunitec.com)

E-Mail: [Info@csunitec.com](mailto:Info@csunitec.com)

## Chain Repair Terms

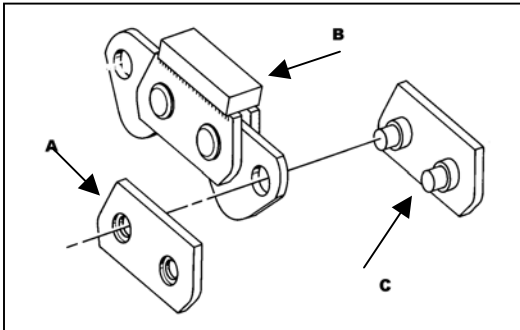

- A. Connecting link.
- B. Diamond segment with bumper drive link.
- C. Preset connecting link with rivets.

## Chain Breaker Description

Part No. CS 70026

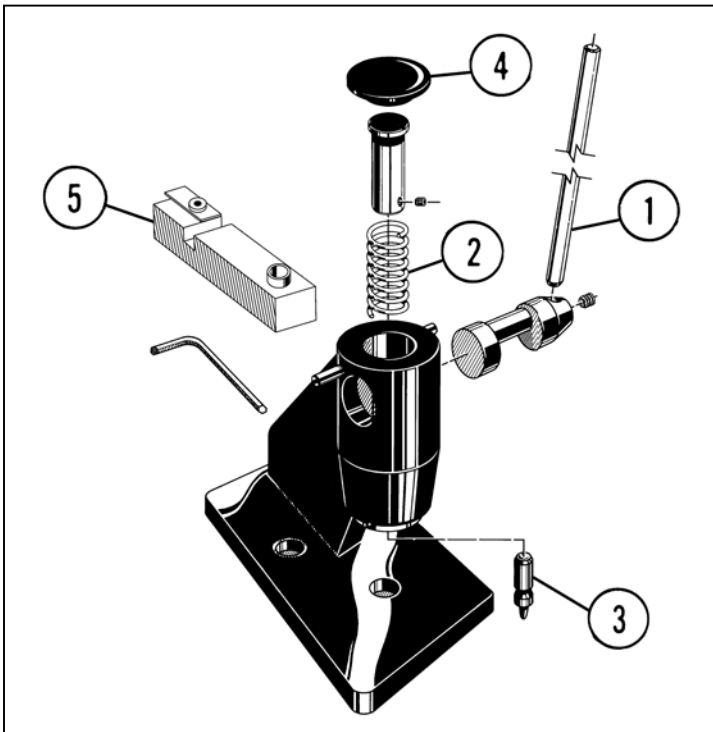

Drives out rivets easily with one pull of the handle.

Item No.	Part No.	Description
	CS 70026	Bench-model Chain Breaker
1	CS 71252	Handle
2	CS 38593	Spring
3	CS 71251	Punch
4	CS 38595	Cap
5	CS 70100	Anvil

**CS UNITEC, Inc.**

22 Harbor Avenue, Norwalk, CT 06850

Tel: (203) 853-9522, Toll Free: (800) 700-5919, Fax: (203) 853-9921

Website: [www.csunitec.com](http://www.csunitec.com)

E-Mail: [Info@csunitec.com](mailto:Info@csunitec.com)



**Warning:**  
Safety information

- To avoid possible injury to operator and/or bystanders, carefully read all instructions concerning assembly, operation, and maintenance of this tool.
- Make certain that chain breaker has been mounted securely on flat, clean working surface. Check mounting regularly.
- Check components on chain breaker regularly for wear and general condition.
- Wear eye and hand protection when using this tool.

## OPERATING INSTRUCTIONS

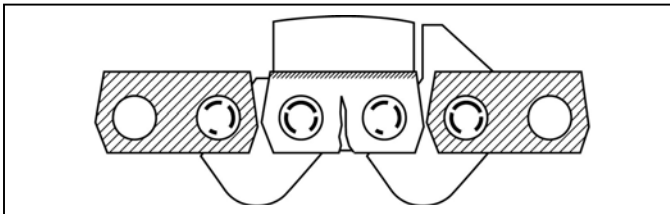

## How to Break Chain

**NOTICE:** Only designed to remove rivet head on connecting link, not segment.

- To replace broken or damaged diamond segment section, punch out the rivets only shown on shaded areas.

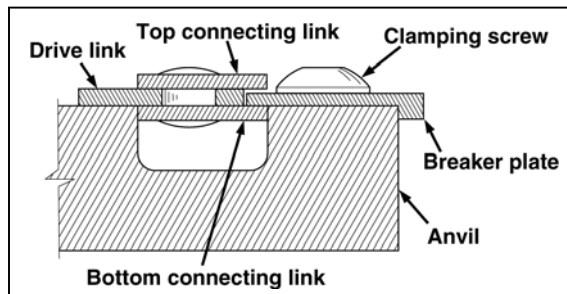
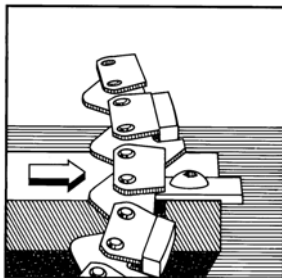

**Step 1.** Insert chain portion for breaking into the slot of the chain anvil and push chain forward until bottom connecting link is flush with far side of slot.

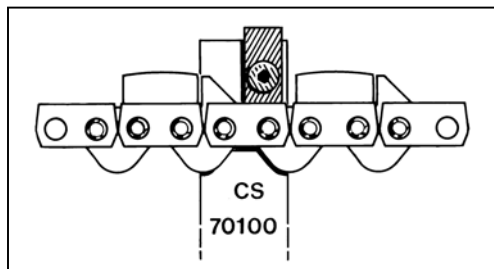
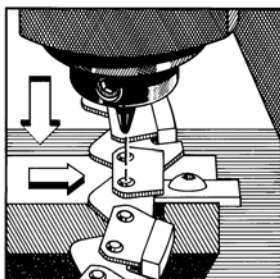

**Step 2.** Position rivet head directly under punch and pull handle (1) down just far enough to push rivet out (do not use excessive force).

**CS UNITEC, Inc.**

22 Harbor Avenue, Norwalk, CT 06850

Tel: (203) 853-9522, Toll Free: (800) 700-5919, Fax: (203) 853-9921

Website: [www.csunitec.com](http://www.csunitec.com)

E-Mail: [Info@csunitec.com](mailto:Info@csunitec.com)

## Chain Repair Kit

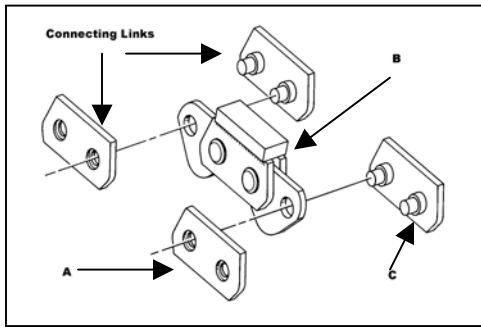

Part No. 72256

Part No. 72259 (Connecting link 5 pack)

Chain repair kit consists of the following chassis parts:

- A. Connecting link (2)
- B. Diamond segment with bumper drive link (1)
- C. Preset connecting link with rivets (2)

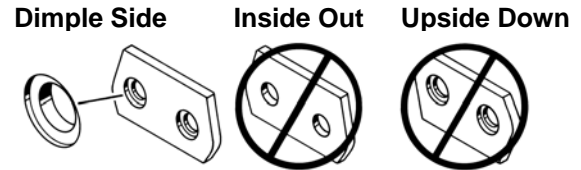

**NOTICE:** Dimple side out

## Rivet Spinner Description Part No. CS 70024

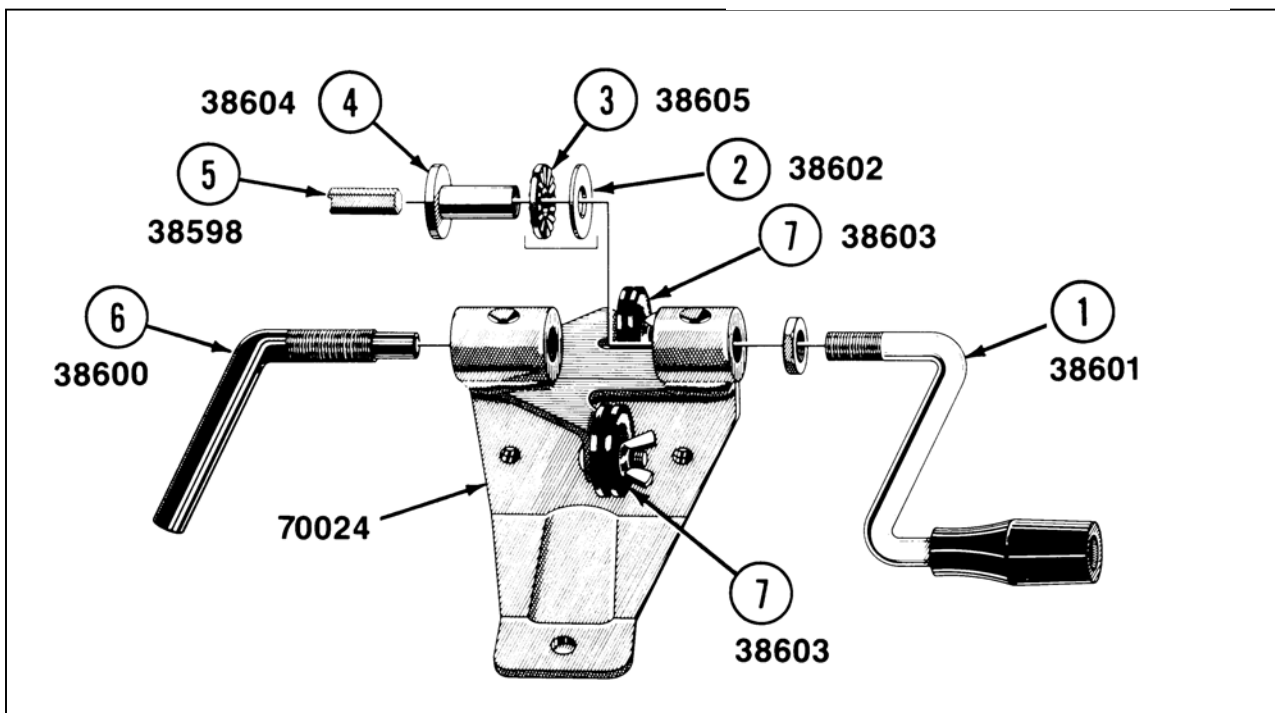

Rivet Spinner is the very best tool for joining chain. Produces tight consistent rivet spins every time. Minimizes risk of chain breakage.

Item No.	Part No.	Description
	CS 70024	Bench-model Rivet Spinner
1	CS 38601	Spinner Handle with Grip
2	CS 38602	Shim
3	CS 38605	Thrust Bearing
4	CS 71253	Sleeve
5	CS 71250	"B" Anvil
6	CS 71249	"B" Take-up Handle
7	CS 38603	Chain Support Disk

## Rivet Spinner



### Warning: Safety information

- To avoid possible injury to operator and/or bystanders, carefully read all instructions concerning assembly, operation, and maintenance of this tool.
- Make certain that rivet spinner has been mounted securely on flat, clean working surface. Check mounting screws/bolts regularly.
- Check components on rivet spinner regularly for wear and general condition.
- Wear eye and hand protection when using this tool.

### OPERATING INSTRUCTIONS – How to Spin Rivets

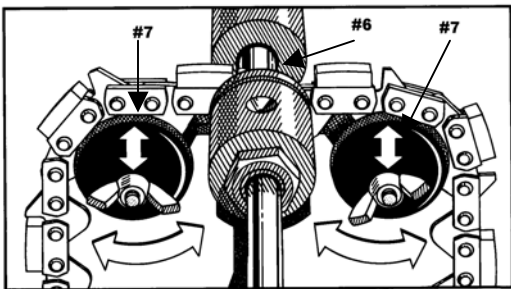

**Step 1.** Lay chain across plastic chain supports (#7) and rotate supports so the rivet head is centered between take-up handle (#6) and spinner anvil (#5).

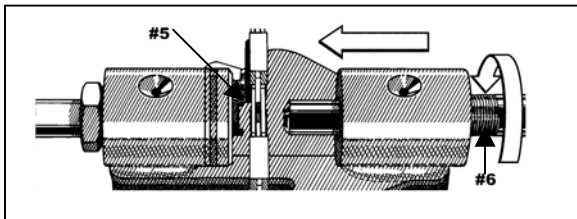

**Step 2.** Turn take-up handle (#6) until chain is secured against spinner anvil (#5).

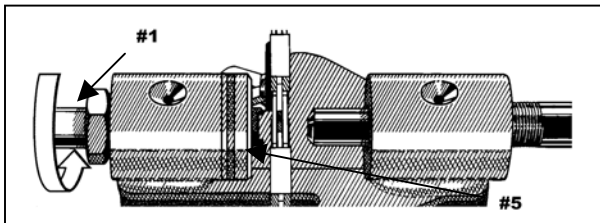

**Step 3.** Turn spinner handle (#1) a few times to center the rivet hub in the spinner anvil (#5).

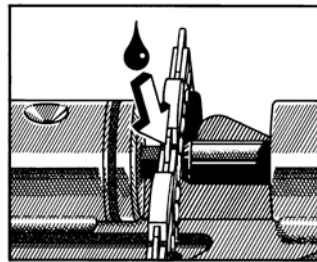

**Step 4.** Apply a few drops of oil to the rivet hub.

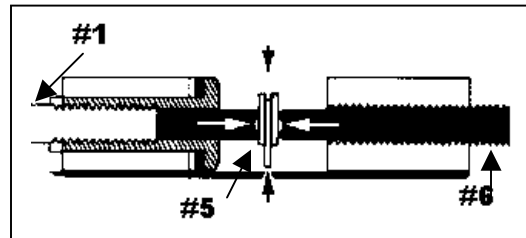

**Step 5.** Turn spinner handle (#1) and, at the same time, slowly turn take-up handle (#6) inward (approximately one full revolution) until rivet head is formed. Take-up handle (#6) provides pressure while spinner anvil (#5) forms rivet head.

### MAINTENANCE

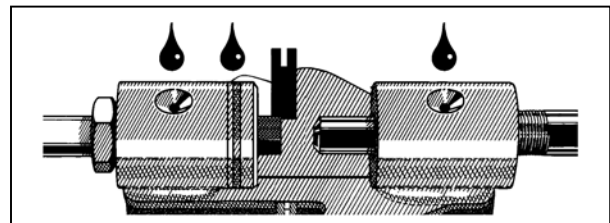

**NOTICE:** This unit is equipped with oiling chambers and should be maintained periodically with a lightweight oil.

## Bar Terms

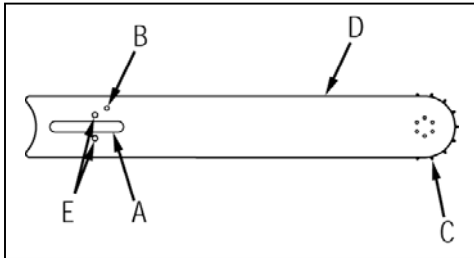

- A. Bar mounting slot
- B. Water Inlet hole
- C. Sprocket nose
- D. Bar rails (hard surfaced)
- E. Chain tension mounting holes

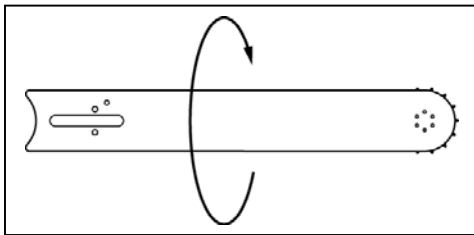

- Bar is designed to be used on both sides. When worn out on one side, turn bar over.
- Cover chain and bar with oil for long periods of storage.
- Proper chain tension will extend bar life.

## NOSE SPROCKET MAINTENANCE

- Nose sprocket and bar body can be expected to wear out under normal working conditions.
- Under normal circumstances, sprocket nose life is less than the bar body life.
- More life and value can be obtained from your bar body by replacing a damaged or worn sprocket nose. See page 6.

Using a belt sander or grinder, remove wire edges that form on rails. Left alone, wire edges can reduce kerf width and affect cutting performance.

**NOTICE:** The bar is solely a guide track for your chain. Never use the bar as a lever to lift, twist or pry.

## NOSE SPROCKET

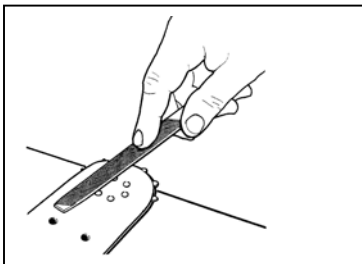
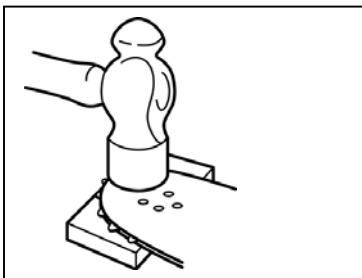
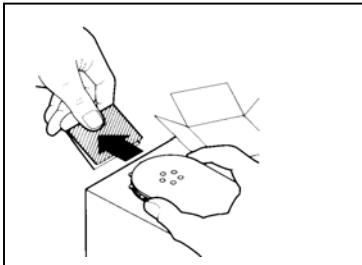
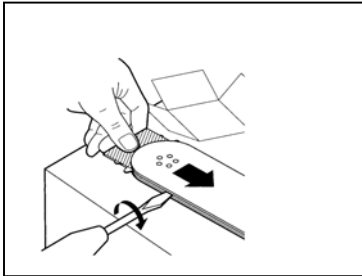
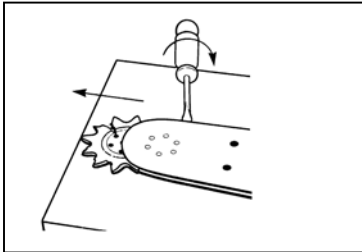
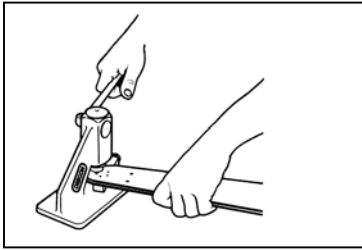

**Step 1.** To remove bar nose rivets. Use the CS Unitec chain breaker P/N CS 70026. Insert anvil (pilot plug) P/N CS 70100 into the 1/2" dia. Hole on the base of the chain breaker. Center bar rivet over the 1/4" dia. hole on the anvil and punch rivet.

**Step 2.** Remove the old nose sprocket. Insert a straight blade screwdriver to spread the bar nose rails just enough to remove the old nose sprocket. Use a rag or paper towel to clean the nose sprocket area.

**Step 3.** Prepare to insert the new nose sprocket. Open the new nose sprocket package, folding back the top portion of the insertion card being careful not to remove or disturb the components.

**Step 4.** Insert the new nose sprocket. With the screwdriver in the bar nose rails, slide the nose sprocket assembly into position, aligning the 6 holes in bar nose with the 6 holes in the nose sprocket assembly without removing the components from the card. Insert 6 nose rivets into holes and hold down with thumb. Remove the screwdriver and slide out the insertion card.

**NOTICE:** On used bars the nose rails may tend to spread apart. Use a small clamp if necessary to holds the rails together.

**Step 5.** Peen the nose rivets. With the bar and rivets solidly supported on a strong flat steel surface, carefully peen the rivet heads down with the flat end of a hammer. Be careful to hit only the rivet head. Do not hit the bar body – this will pinch the nose sprocket. Rivet heads must completely fill the countersinks in the bar body and be snug and secure while still allowing the sprocket to turn freely.

**Step 6.** File the rivet heads. Use a flat file to file all of the rivet heads to a uniform height. Rivets should be flush to bar body.

**CS UNITEC, Inc.**

22 Harbor Avenue, Norwalk, CT 06850

Tel: (203) 853-9522, Toll Free: (800) 700-5919, Fax: (203) 853-9921

Website: [www.csunitec.com](http://www.csunitec.com)

E-Mail: [Info@csunitec.com](mailto:Info@csunitec.com)