



PLEASE SPECIFY TOOL MODEL # WHEN ORDERING PARTS

PARTS BREAKDOWN	Model #: 5 1212 0050	Bulletin #: 09-2017
PARTS LISTING	Description: Air Hacksaw w/ Lever Handle	Prepared By: SCW
WIRING DIAGRAM	Date: 4/25/2017	

5 1212 0050 Hacksaw

Position	QTY	Description	Part #
		Lock Pin Assembly	3-34-12-015-01-9 5 1201 7920
		Crankshaft Assembly	3-34-05-022-02-8 5 1202 4930
		Connecting Rod	3-27-14-057-01-1 5 1202 4950
		Motor, Complete	5 1212 1000
5 + 6		Pin, Locking	4-02-38-042-00-8 9 1642 0080
65 + 89		Screw	4-30-35-073-052 & 4-30-35-093-05 9 1110 3120
66 + 95		Locking Plate	4-24-43-004-05-7 9 3329 0010
1		Compressed Air Motor	3-13-05-176-01-4 5 1202 1910
2		O-Ring	4-06-12-058-00-5 9 1901 4170
3		O-Ring	4-06-12-059-00-9 9 1901 4180
4		Cylinder Bushing	3-13-05-180-00-3 1 1430 1020
7		End Plate	3-13-05-182-00-5 5 1202 1100
8		Bearing	4-17-01-007-05-0 9 1003 0020
9		Ring, Snap	4-26-16-027-00-9 9 1703 0070
10		Shim	3-13-05-183-00-9 5 1202 1080
11		Rotor	3-13-05-265-00-9 5 1212 1030
12		Vane (4 Required)	3-13-05-185-00-1 1 1430 1050
13		End Plate	3-13-05-186-00-4 5 1202 1110
14		Bearing	4-17-01-010-05-4 9 1003 0010
15		Ring, Snap	4-26-16-001-00-5 9 1703 0050
16		Packing Washer	3-13-05-187-00-8 5 1202 1130
17		Felt Strip	3-13-05-188-00-6 9 1902 0470
18		Rotary Sleeve	3-13-05-189-00-0 5 1202 1120
19		Weight Clip	3-13-05-266-00-2 1 1430 2020
20		Governor Weight	3-13-05-267-00-6 1 1834 2030
21		Pin	3-13-05-268-00-4 9 1619 0150
22		Spring	3-13-05-269-00-8 9 1803 2690
23		Governor Basket	3-13-05-270-00-0 1 1430 2160
24		Nut	3-13-05-271-00-9 1 1430 2050



PLEASE SPECIFY TOOL MODEL # WHEN ORDERING PARTS

PARTS BREAKDOWN	Model #: 5 1212 0050	Bulletin #: 09-2017
PARTS LISTING	Description: Air Hacksaw w/ Lever Handle Prepared By: SCW	
WIRING DIAGRAM	Date: 4/25/2017	

5 1212 0050 Hacksaw

Position	QTY	Description		Part #
25		Governor Casing, Complete	3-13-05-339-00-7	5 1212 2010
26		O Ring (See P/N 237 469)	4-06-12-060-00-1	9 1901 3130
27		Screw	4-30-33-064-06-6	9 1112 4020
28		Twist Throttle FOR HACKSAW	3-13-05-200-02-2	9 2008 0050
30		Gear Housing	3-12-09-013-00-2	5 1205 4910
34		Ball Bearing, Grooved	4-17-01-607-01-2	9 1002 0070
35		Drive Head	3-01-10-021-00-9	5 1202 4030
36		Pin	3-02-16-099-00-6	5 1202 4050
37		Gear Wheel	3-36-13-075-003	5 1202 4040
38		Needle Cage for Air Hacksaw		9 1015 0300
41		Gear Rim	3-38-04-015-00-5	5 1202 4020
42		Screw, Cylindrical	4-30-02-108-99-7	9 1115 1020
43		Bearing	4-17-01-010-03-2	9 1003 0370
44		Key	4-02-21-008-00-3	9 1501 1120
45		SNAP RING	4-26-41-001-00-2	9 1702 0090
46		Bevel Gear Complete	3-38-09-142-01-9	5 1202 4920
47		Washer	3-26-24-087-02-8	5 1202 4140
47		Balance Ring	3-26-24-087-03-4	5 1202 4340
49		Balance Ring		5 1202 4150
49		Balance Ring	3-26-24-086-03-0	5 1202 4350
50		Feather	4-02-21-017-00-4	9 1501 2080
51		Crankshaft	3-34-05-022-00-3	5 1202 4160
52		Pin	3-02-17-200-00-4	5 1202 4170
53		BEARING	4-17-24-001-00-5	9 1025 0200
55		WASHER	3-24-08-212-00-6	5 1202 4490
56		Retaining Ring	4-26-16-006-00-7	9 1702 0050
58		Bearing	4-17-01-222-03-8	9 1004 0270
59		Nut, Hexagon	4-20-19-006-08-0	5 1202 4210
62		Bearing Plate-OLD#5 1202 4220	3-24-19-063-00-0	5 1213 4220
63		Snap Ring	4-26-16-003-00-2	9 1703 0120



PLEASE SPECIFY TOOL MODEL # WHEN ORDERING PARTS

PARTS BREAKDOWN	Model #: 5 1212 0050	Bulletin #: 09-2017
PARTS LISTING	Description: Air Hacksaw w/ Lever Handle	Prepared By: SCW
WIRING DIAGRAM	Date: 4/25/2017	

5 1212 0050 Hacksaw

Position	QTY	Description		Part #
64		Pin, Notched Taper	4-02-47-006-00-2	9 1626 0180
68		Washer	3-24-08-232-00-4	9 3302 0030
69		Grooved Pin	4-02-47-007-00-6	9 1626 0060
70		Gear Casing Cover Complete	3-24-29-068-01-9	5 1202 4940
72		Lock Pin Assembly	3-34-12-015-01-9	5 1201 7920
73		Locking Pin	3-34-12-015-00-0	5 1202 4200
74		Sleeve	3-05-10-025-00-4	5 1202 4230
75		Pressure Spring	3-09-01-113-00-8	9 1803 0300
76		Ring	3-26-01-193-00-8	5 1202 4250
77		Connecting Rod	3-27-14-057-00-2	5 1202 4260
78		Connecting Link	3-27-14-059-00-4	5 1202 4270
79		Fillister Head Screw	4-30-35-080-06-8	9 1110 4040
80		Cylindrical Pin	4-02-01-036-00-6	9 1619 0180
81		Threaded Pin	4-30-07-038-08-8	5 1202 4280
82		Pressure Plate	3-27-14-011-00-0	5 1201 7060
83		Nut Hexagon		9 1203 0050
84		Disc	4-24-01-003-06-3	9 3302 0020
85		Clamping Sleeve	4-02-38-014-00-3	9 1632 0010
86		Spring Washer	4-24-45-003-06-0	9 3312 0010
87		Nut Hexagon	4-20-01-029-06-6	9 1203 0040
88		Screw	4-30-33-015-05-2	9 1110 3030
90		Bushing, Brass	3-16-04-008-00-1	5 1206 4300
91		Scraper	3-27-14-058-00-0	9 1902 0490
92		Felt	3-06-04-042-00-7	9 1902 0500
93		Stay Bolt	3-30-23-060-00-5	9 1643 0010
94		Nut	4-20-19-005-05-2	9 1211 0020
96		Handle	3-21-19-044-01-2	5 1202 6000
97		Screw	4-305-507-305-2	9 1112 3090
98		Fillister Head Screw		9 1110 3080
301		Valve Box Assembly	3-13-05-200-01-6	1 1901 3920



PLEASE SPECIFY TOOL MODEL # WHEN ORDERING PARTS

PARTS BREAKDOWN	Model #: 5 1212 0050	Bulletin #: 09-2017
PARTS LISTING	Description: Air Hacksaw w/ Lever Handle	Prepared By: SCW
WIRING DIAGRAM	Date: 4/25/2017	

Hacksaw Safety Lever Handle

Position	QTY	Description		Part #
101		Valve Housing Complete	3-13-05-332-01-1	2 2045 3910
102		Ring	3-13-05-333-00-6	1 2134 3050
103		Valve Bushing	3-13-05-334-00-4	1 1901 3050
104		Sleeve	3-13-05-336-00-1	1 2034 3060
105		Pin	3-13-05-336-00-1	1 2034 3070
106		O-Ring	4-06-12-065-00-9	9 1901 2020
108		Spring	3-13-05-338-00-3	9 1803 2170
109		Nipple	3-13-05-339-00-7	9 2205 1060
110		O Ring	4-06-12-155-00-9	9 1901 3280
111		Valve Lever	3-13-05-340-00-9	1 1901 3030
112		Rivet	3-13-05-341-00-8	9 1611 0040
114		Differential Piston	3-13-05-342-00-1	1 2034 3920
115		O-Ring	4-06-12-156-00-2	9 1901 3550
116		O-Ring	4-06-12-113-00-1	9 1901 3110
117		O-Ring	4-06-12-157-00-6	9 1901 3240
118		Pressure Spring	3-13-05-343-00-5	9 1803 0780
119		Guide Bushing	3-13-05-344-00-3	1 2034 3100
120		O-Ring	4-06-12-158-00-4	9 1901 2380
122		Oiler Tube	3-13-05-345-00-7	2 2045 3110
125		Filler Plug,	3-13-05-208-00-0	9 1150 9020
126		Sealing ring	3-13-05-212-00-8	9 1903 0340
127		Screw	3-13-05-211-00-5	9 1150 9030

5 1212 0050 Hacksaw

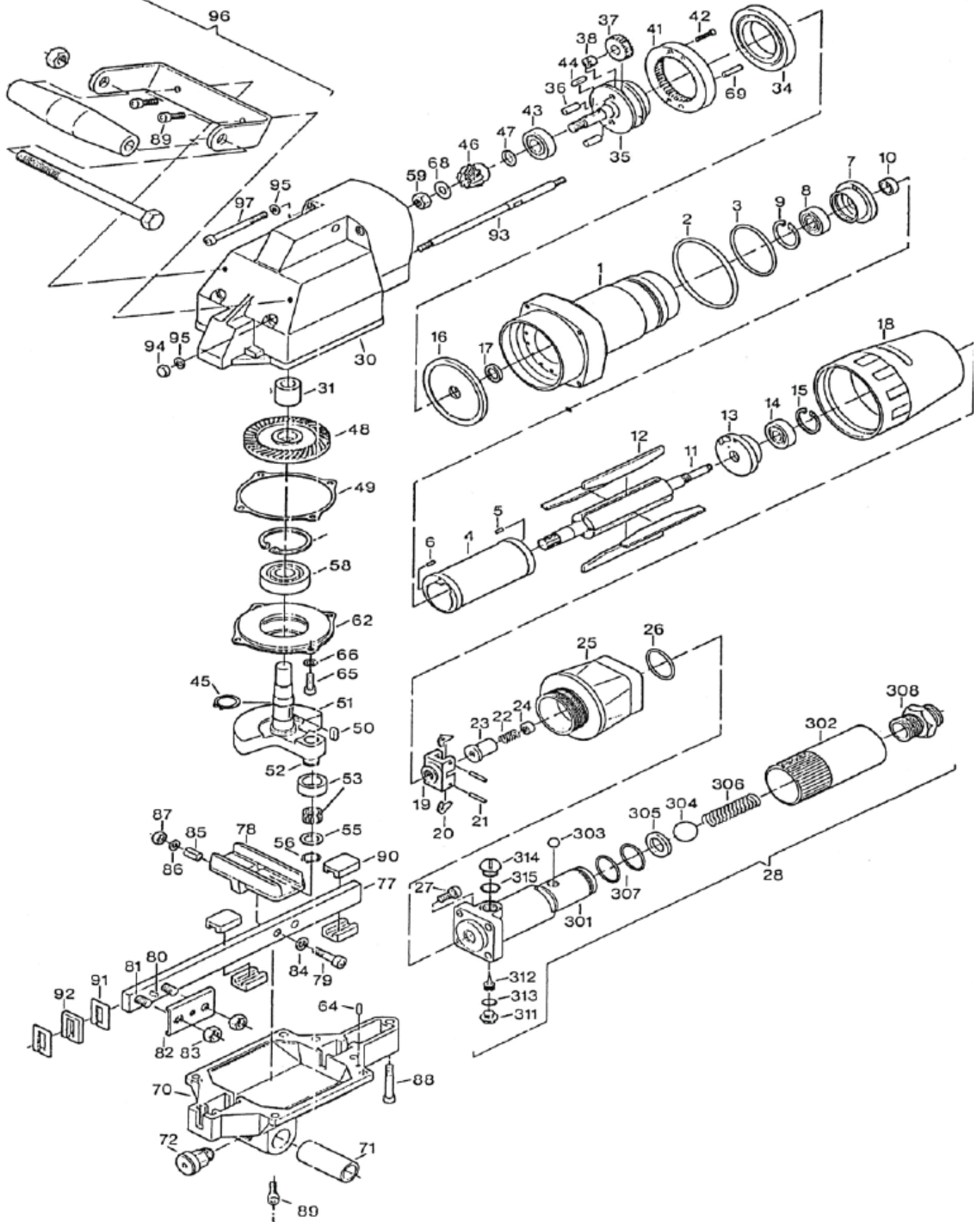

Hacksaw Safety Lever Valve

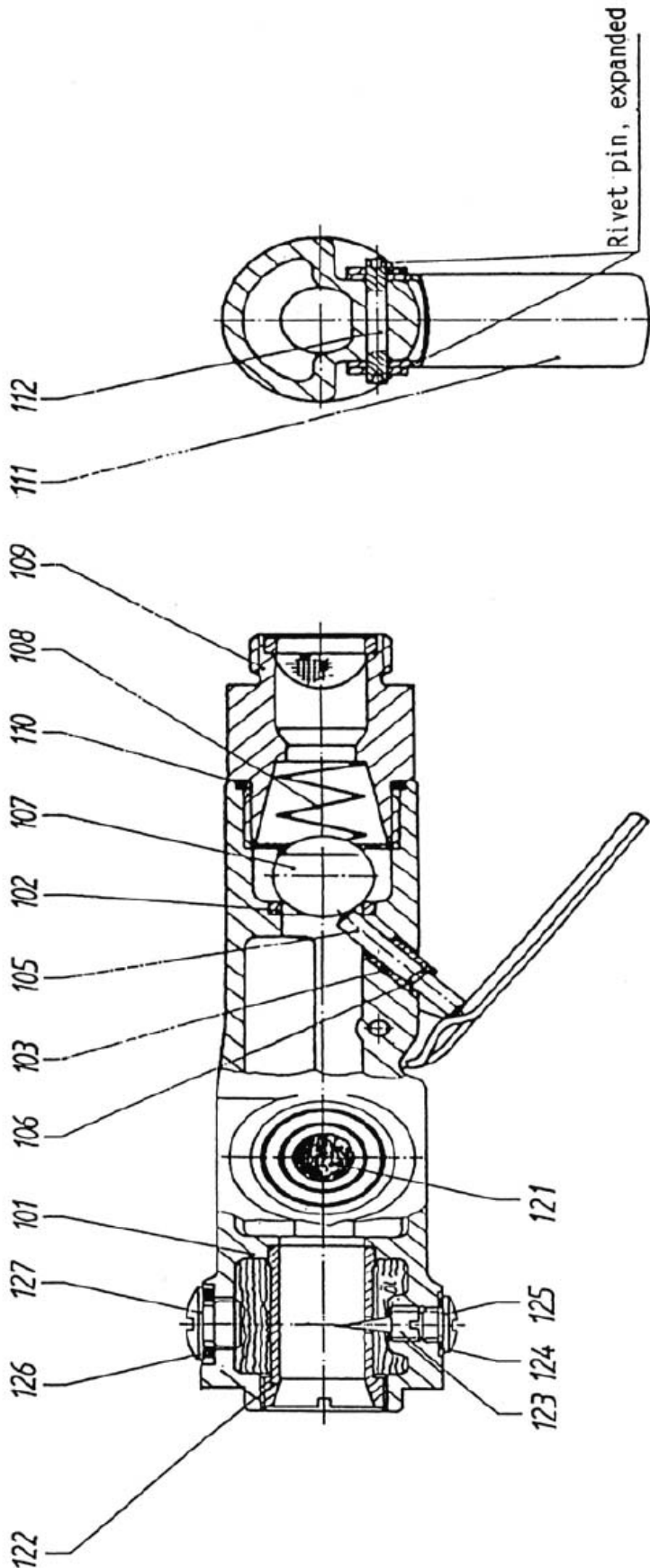

Safety Lever Valve R 3/4" with Oiler
 Type 9 2007 0080

