

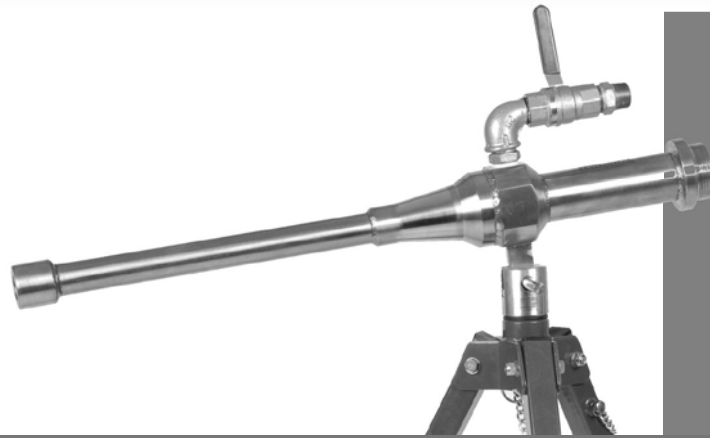

## HYDRAFLEX HOLD CLEANER



## OPERATION & MAINTENANCE



# OPERATION

## Foreword

Thank you for purchasing the Hydraflex Hold Cleaner.

This manual contains the necessary maintenance information for you to ensure proper operation and care for your machine.

**It is essential for you to read through these manuals thoroughly.**

In the unlikely event that you experience problems with your Hydraflex, please do not hesitate to contact your local dealer or agent.

We always welcome feedback and comments from our valued customers.

## General Information

Before operating, performing maintenance or repairing the Hydraflex Hold Cleaner this manual must be read and understood by the operator, if in any doubt, ask your supervisor before using this equipment.

Local safety regulations must be followed at all times. Failure to follow these instructions could result in damage to the Hydraflex Hold Cleaner and/or personal injury.

Trelawny SPT Limited disclaims all responsibility for damage to persons or objects arising as a consequence of incorrect handling of the machine, failure to inspect the machine for damage or other faults that may influence the operation prior to starting work, or failure to follow the safety regulations listed or applicable to the job site.

The tool is primarily designed for the cleaning/washing of ships cargo holds; it produces a powerful jet of water, which can also remove flaking rust and paint.

Operators should be familiar with the data given in the specification section.

Please keep these instructions in a safe and accessible place.

## Safety

**Do** wear Personal Protective Equipment including safety goggles, footwear, ear defenders and gloves. In some environments it will be necessary to wear facemasks or breathing apparatus.

**Do** be aware that this tool is not electrically insulated.

**Do** be aware that this tool can create flying debris.

**Do** be aware of others working around you.

**Do** store this tool in a secure and dry place.

**Always observe safe working practices and local safety regulations at all times.**

**Never** aim the Hydraflex hold cleaner at any person, this equipment produces a very powerful jet of water and can cause serious injury if misused.

**Do not** operate the Hydraflex, unless it is securely fixed to its tripod and situated on a flat surface.

**Do not** modify this tool in any way, as this will invalidate the warranty and could lead to serious injury.

**Do not** drag this tool by the water or air hose.

**Please note:** Unrestrained air and water hoses can whip if they become detached.

## Water Supply

Ensure that a minimum 51mm (2.0") bore water hose is used and that all couplings are secure, leak free and in good condition.

**The recommended water pressure is 5.9 bar (85p.s.i.).**

## Air Supply

Ensure that a minimum 19mm (3/4") bore air hose is used and that all couplings are secure, leak free and in good condition.

Limit the length of air hose to 30M (100ft). Where extra length is necessary, for each additional 15M (50ft) of air hose used, the pressure drop is approximately 0.21bar (3psi).

**Recommended air pressure is 6.9bar (100 psi).**

Do not let the operating pressure fall below 6.2bar (90p.s.i.) or rise above 7.6bar (110 psi)

Preferably, the compressor should be able to supply a minimum of 47.2 L/s (100cfm) free air.

## Starting Work

Prior to operating the tool check: -

That all fittings are secure, free from leaks and air hoses are in good condition.

**That the air pressure is correct for this tool 6.9 bar (100 psi).  
That the water pressure is correct for this tool 5.9 bar (85psi).**

Safe use of this tool requires that the operator adopt a solid stance and secure foothold.

Gloves and personal protective equipment **must** be worn when using this tool.

Care must be taken to avoid damaging or tripping over the air or water hose.

Erect the tripod and spread the tripods legs fully, ensure that the tripod is placed in a stable position.

Remove the safety pin from the swivel pin and remove the swivel pin from the tripod, attach the Hydraflex to the tripod securing it with the swivel pin, replace the safety pin.

# OPERATION

## Pre-Start Check

Always clear the air hose before connecting it to the Hydrflex, this is to ensure the removal of any foreign bodies that may be present, which would otherwise block, or choke the valve assembly.

Connect a 51mm (2.0") water hose to the rear of the Hydrflex using the hose adapter or fit one of the supplied instantaneous couplings to the hose and connect to the adapter.

**IMPORTANT:** Take precautions to ensure that the area to be cleaned is completely free of personnel and of any electrical equipment that is exposed or is not protected against water ingress (IP67 minimum protection).

## Machine Operation

With one operator securely holding and controlling the Hydrflex a second person should slowly open the water valve at the main or pump.

It is very important that the Hydrflex be held securely while the water is being turned on and while it is in use.

The air valve should now be adjusted carefully to produce a tight hard-hitting jet of water. Excessive air will cause the jet of water to break up and spread, becoming less effective.

In an emergency or once cleaning has been completed, close the air valve and instruct the second operator to shut off the water supply.

Disconnect the air and water hoses and wipe all deposits from the outside of the Hydrflex.

Remove the safety pin and then taking the weight of the Hydrflex, remove the swivel pin from the tripod and remove the Hydrflex. Replace the tripod swivel pin and replace its safety pin.

When collapsing the tripod, take care not to trap fingers or hands. It is recommended that the joints and swivel head of the Tripod be lubricated prior to storage.

Cover the Hydrflex hold cleaner to protect it and store in a secure and dry place.

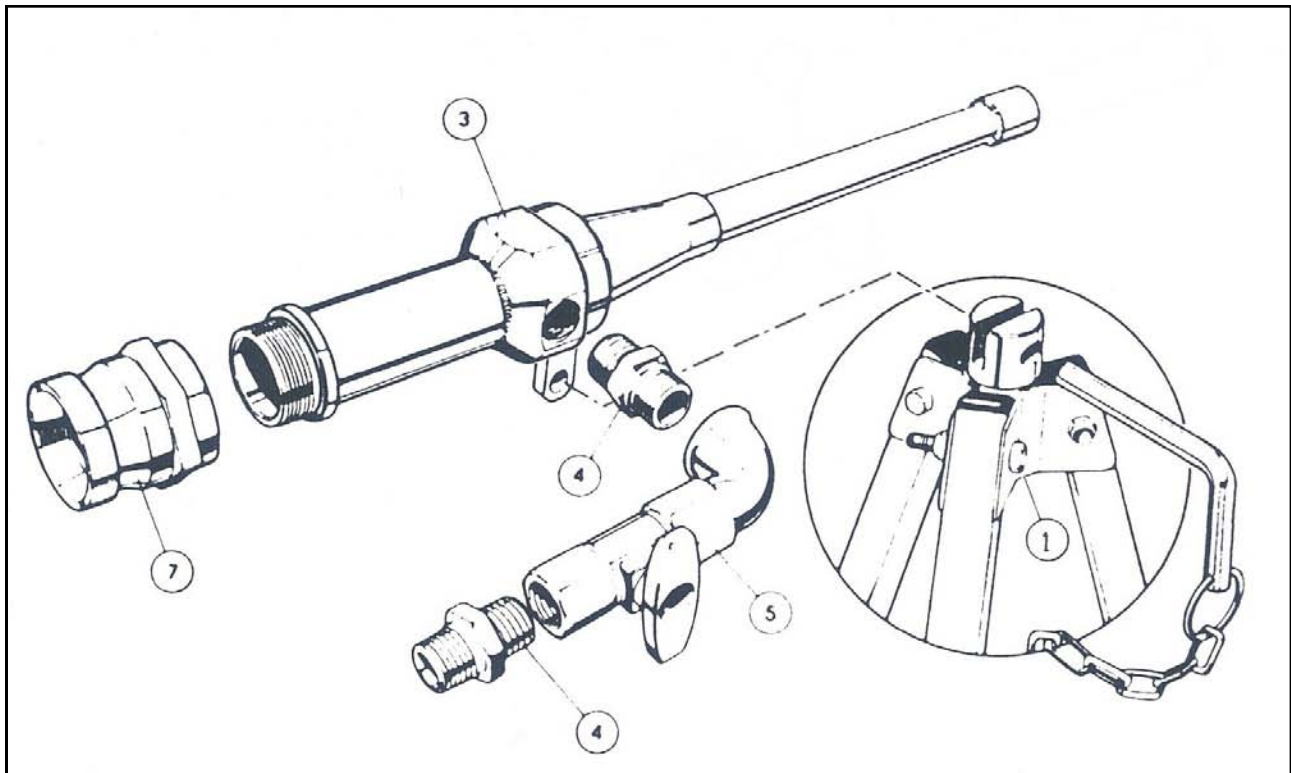

Item No:	Part No:	Description
1	342.HY02	Tripod
3	342.HY35	Main Body
4	342.HY16	Air inlet adapter
5	828.1000	Air inlet control valve
7	342.HY05	Instantaneous water hose adapter
7a	342.HY03	Water hose coupling 2½" x 2½"
7b	342.HY04	Water hose coupling 2½" x 2.0"

# SPECIFICATION

If your company has a problem or would like to discuss the possibility of an improvement being made to the Hydrflex, then please do not hesitate to contact us.

Your comments are both important and appreciated.

## Technical Specifications

**At its maximum working distance of 30 metres, the force of water on the surface being cleaned is approximately 10kg**

Recommended water pressure	6kg/cm <sup>2</sup> (5.9 bar)	85 psi
Recommended air pressure	7kg/cm <sup>2</sup> (6.9 bar)	100 psi
Estimated water consumption	454 lpm	100 gal/min
Estimated air consumption	33 lps	70 cfm
Recoil	10 to 18 kg.	22 to 40 lbs
Weight (Hydrflex & tripod)	14.1 kg.	31 lbs.
Weight of Hydrflex	5.5 kg.	12 lbs.
Weight of Tripod	8.6 kg.	19 lbs
Length of Hydrflex (including threaded adapter)	770 mm	30"
Length of tripod (closed)	1160 mm	45.5"
Height of tripod (open)	1027 mm	40.5"
Air hose (minimum internal diameter)	20 mm	¾"
Water hose (minimum internal diameter)	51 mm	2"
Instantaneous coupling (use water hose adapter)	2½" BSP x 2"	
Instantaneous coupling (use water hose adapter)	2½" BSP x 2½"	

All rights reserved. Any unauthorised use or copying of the contents or part thereof is prohibited.

This applies to trademarks, model denominations, part numbers and drawings.

Use only genuine Trelawny spares.

**The use of non-Trelawny spare parts invalidates the warranty.**



# TRELAWNY

**SURFACE PREPARATION TECHNOLOGY**



*Distributed exclusively by:*

## UNITEC

22 Harbor Avenue, Norwalk, CT 06850 USA

Toll-Free: 800-700-5919

Phone: 203-853-9522

Fax: 203-853-9921

Email: [info@csunitec.com](mailto:info@csunitec.com)

[www.csunitec.com](http://www.csunitec.com)