



## **VL223 CHALLENGER NEEDLE & CHISEL SCALERS**



## **OPERATION & MAINTENANCE**



# OPERATION

## General Information

Before operating, performing maintenance or repairing the VL223 Needle/Chisel Scalers, this manual must be read and understood. If in any doubt, ask your supervisor before using this equipment.

Local safety regulations must be followed at all times. Failure to follow these instructions could result in damage to the Scaler and/or personal injury.

Operators should be familiar with the data given in the specification section. Please keep these instructions in a safe and accessible place.

Trelawny SPT Limited disclaims all responsibility for damage to persons or objects arising as a consequence of incorrect handling of the tool, failure to inspect the tool for damage or other faults that may influence the operation prior to starting work, or failure to follow the safety regulations listed or applicable to the job site.

The tool is primarily designed for the removal of paint, rust, scale, and for the removal of laitance from concrete, it can be used both indoors and out.

This tool must not be used in a fixture.

## Air Supply

The compressed air must be free from water and dirt. The installation of a filter/regulator/lubricator air preparation set (with moisture trap) adjacent to the tool is **strongly recommended**.

In particularly cold temperatures it is recommended that a proprietary anti-freeze lubricating oil is used.

Always clear the air hose before connection to the tool. Ensure that no moisture (condensation) is present in the air hose.

Ensure that only 10mm (3/8") bore air hose is used and that all couplings are secure, leak free and in good condition.

For maximum efficiency, limit the length of air hose to 10M (33ft). Where extra length is necessary, for each additional 15M (50ft) of air hose used, the pressure drop is approximately 0.16bar (3psi).

**The correct air pressure for this machine is to 6.2bar (90psi).**

Do not let the operating pressure fall below 5.5bar (80p.s.i.) or rise above 6.9bar (100 psi) absolute maximum.

The compressor should be able to supply a minimum of 3.77 L/s (8cfm) of **free air** not displaced as quoted by some compressor manufactures, this will give 3cfm of headroom, so that the compressor isn't continually running.

### NOTE:

**If this tool stops working**, it is most likely that the plastic (17) ball has worn excessively and may have passed into the cylinder, check the cylinder exhaust holes for the remnant also. This is designed to run for approximately 160hrs before requiring replacement. (Spare balls are supplied with the tool)

## Safety

**Always, read instructions first before use.**

### Do -

Be aware that this tool is **not** electrically insulated.

Be aware that the tool can create dust and flying debris.

Keep hands and clothing away from moving parts.

Be aware of others working around you.

Ensure that this tool is lubricated **daily**.

Store this tool in a secure and dry environment.

Wear Personal Protective Equipment including safety goggles, footwear, ear defenders and gloves.

In some environments it will be necessary to wear facemasks or breathing apparatus. (Vacuum shroud available)

**Always observe safe-working practices at all times.**

### Do not -

Allow the tool to run unattended.

Use the Scaler as a lever.

Modify this tool in any way, this will invalidate the warranty and could also lead to serious injury.

Use wire or any other fixing to lock the throttle lever in the on/open position.

Operate tool with the front tube (34) removed.

Use the tool in potentially explosive environments.

Drag the tool by the air hose.

Use petrol (gasoline), thinners or any other high flash point solvent to clean the tool.

Use the tool if you become tired, this can lead to physical strain or injuries; where practical; use a spring balance, balance weights or similar equipment to take the weight of the tool.

Hold the exposed needles or chisel, whilst the tool is in use, this could cause vibration damage to the hands.

**Please note:** Unrestrained hoses can whip if they become detached.

Care must be taken to avoid damaging or tripping over the trailing air hose.

## Starting work

Please note,

The Carbon steel needles provided are not intended for use in a potentially explosive atmosphere.

### Prior to operating the tool check: -

That all fittings are secure, free from leaks and air hoses are in good condition.

**That the air pressure is correct for this tool 6.2 bar (90 p.s.i.).**

Put a few drops of a recommended lubricant into the air inlet of the tool.

Safe use of this tool requires a solid stance and secure foothold, the tool may be used in other postures but care must be taken that the operator adopts a firm and stable position.

Maintain contact with the work surface with sufficient pressure only to keep the tool from bouncing.

Excessive pressure can prevent the tool from working to its full capacity.

Handled correctly the VL223 Needle Scalers will work quickly and efficiently.

# MAINTENANCE

**Excessive operator pressure will not improve the tool efficiency but could cause premature tool failure and operator fatigue.**

Never allow the tool to run continuously whilst not in contact with the surface being prepared.

To operate the tool, pull the throttle lever towards the handle and then apply the needles to the surface to be worked.

Do not place needles on the surface, and then pull the throttle lever as this will result in the tool bouncing off the surface.

**To switch off, simply release the throttle lever.**

Gloves and personal protective equipment **must** be worn when using this tool.

## Maintenance

**Maintenance** must only be carried out by a competent person, in a suitably equipped workshop.

**Disconnect the tool from the air supply before carrying out any of the following operations.**

Clean all debris from the exterior of the tool.

This tool has been designed so that you only require a vice, screwdriver, 3mm pin punch and light hammer, no other specialist tools are required to completely strip and service the tool.

For safe efficient running and at intervals of no more than 120 hours, dismantle and clean with highly refined paraffin.

Check all components for wear, replace the ball valve (Item 17) and all O'Rings. Immediately after cleaning, thoroughly oil the tool with one of the recommended lubricants.

### Pointed tip needles

Sharpened to a nail point, these are most effective in breaking through very hard scale on surfaces where some surface indentation is permissible - or where keying (i.e. profile) of the surface is desirable. Pointed tip needles are available in 3mm only.

### Chisel tip needles

These are general purpose needles, flattened to a chisel like blade and are most effective in the removal of thicker material, while leaving a less pitted surface than the Pointed tip needles but still giving some surface indentation (i.e. profile). Chisel tip needles are available in 3mm only.

### Flat tip needles

Machined to a flat tip, these needles will leave slight marking (i.e. profile) on the surface; the 2mm needles actually have a burnishing effect on steel.

2mm Needles are recommended for use on thin gauge steels and any softer surfaces such as cast iron and aluminium where light treatment is desired.

Flat tip needles are available in three sizes - 2mm, 3mm and 4mm.

### Removing Needles

Disconnect from air supply, hold the Cover in a vice using the flats provided, keeping the tool horizontal, unscrew by hand, the Front Tube assembly complete with Return Spring (32), Needles, and Needle Holder.

Check the condition of the Front Tube Locking O'Ring (25). Take care not to invert the Needle Scaler while removing the Front Tube or the Piston may fall out of the Intermediate Tube.

Remove the Needles from the Needle Holder and dispose of the used Needles in an appropriate manner.

### Re-fitting the Needles

Insert the new needles into the Needle Holder location holes; ensure that the Needles are inserted into the chamfered side of the holes. Fit new Front Tube Locking O'Ring to the Intermediate Tube. Fit the Return Spring over the needles (31) and insert the Needle assembly into the Front Tube. Screw the Front Tube assembly onto the intermediate Tube until hand tight.

## Recommended lubricants

Oil the tool daily during use. Put a few drops of one of the following bio-degradable air tool lubricants through the air inlet.

SHELL	Naturelle HF
CASTROL	Carelube HTG 22

Always use clean oil from a sealed container.

## Tool Dismantling

Before carrying out any dismantling, ensuring the air supply is turned off, remove the air-line from the tool. Clean all deposits from the outside of the tool. Service kits are available, see parts section.

### Piston and Cylinder removal

Hold the Cover in a vice using the flats provided, keeping the Front Tube (34) horizontal. Unscrewing anti-clockwise by hand, remove the Front Tube complete with the Needles (31), Needle Holder (30) and Spring (32) as an assembly.

**Note:** When removing tool from vice, do not point the front of the tool downward; the piston and cylinder may fall out of the Intermediate Tube causing damage.

Hold a clean lint free cloth over the open end of the Intermediate Tube, remove from vice and tilt the Tube downwards to remove the Piston (26) and Cylinder. Secure the Cover (10) in a vice with the Intermediate Tube in the vertical position, using the flats provided.

Use a suitable 6mm bar through the holes provided, unscrew the Intermediate Tube (22) anticlockwise. Carefully remove the Intermediate Tube from the cover and remove the Cylinder Guide Plate, which is fitted in the cover.

The Cylinder Guide Plate (12) can be pulled out of the cover to gain access to the Guide Plate Seal (13).

# MAINTENANCE

## Cylinder Ball Valve replacement

This is a consumable item and will require replacing after approximately 120 -160 hours use; this is dependant on the cleanliness of the air supply and frequency of lubrication.

**Do not replace this plastic ball with a steel version**, as it will damage the cylinder valve seat and piston valve pin. Remove the ball retaining O'Ring (18) from its groove just inside the bore of the stem using a suitable pointed implement. Remove the ball from the bore, replace and refit new O'Ring into groove.

## Piston Valve Pin replacement

Hold the piston in a vice by the stem, using a pair of pliers break off the valve pin, use a 6mm drill & bit and remove the remainder from the piston. A small socket (4mm) which just fits over the actual pin, will stop damage occurring. Drive the valve pin in up to its shoulder using a vice or a small hammer.

## Valve Body - Valve Stem removal

Hold the Valve Body (6) in a vice using the flats provided. Using a 3 mm diameter punch, drive the Throttle Lever retaining Spring Pin (8) out of the Valve Body (6) and withdraw the Throttle Lever (7). Remove the Valve Cap with O'Ring (2), Valve Spring (3), Valve Stem (4) and the Valve Seat O'Ring (5).

## Valve Body removal

Remove the Front Tube and remove Needle Holder, Needles and Return Spring as per instructions for Needle replacement above. Replace the Front Tube without the Needles etc, onto the Intermediate Tube and screw up until hand tight. Hold the Valve Body flats securely in a vice, with the Cover (10) uppermost. Turn the tool anti-clockwise around the Valve Body by holding the Cover and Front Tube, unscrew the Valve Body from the handle until loose, remove from vice and finally unscrew by hand.

## Fitting of Chisel Holder

The Chisel Holder assembly comprises of an Anvil, Spring, Chisel Holder and the Chisel. Unscrew Needle Holder attachment and remove the assembly complete with the needles etc, take care not to allow the internal components to fall out of the intermediate tube. Separate the Needle holder assembly and remove the spring. To fit the Chisel Holder, first fit the spring onto the Anvil locating against the large shoulder. Fit this assembly into the intermediate tube and locate the large flat face of the Anvil against the front face of the piston. Ensure that the pinch bolt on the Chisel Holder is loose and screw the Chisel Holder fully on to the intermediate tube. Then unscrew slightly to position the boss underneath the tool and tighten the pinch bolt using a 6mm AF Allen key. Turn the knurled collar on the Chisel Holder until the retaining ball is fully visible; insert the Chisel aligning the rebate with the ball. Position the middle of the rebate on the shank of the Chisel with the retaining ball and turn the collar half a turn to lock the Chisel in place. To release the Chisel, rotate the knurled collar until the retaining ball is fully visible and remove the Chisel.

A vacuum shroud is available (See parts list for shroud and cuff) which fits over the front tube. Position the front of the cuff with the needle tips 20mm inside, adjust as the needles wear. Tighten the caphead screw to secure. Use a Trelawny recommended vacuum for 99.9% dust containment.

## Assembly

Ensure all parts are clean and internal parts have a film of recommended lubricant.

Replace any parts that show signs of wear.

If the tool is being fully serviced, it is strongly recommended to change all O'Rings (2), (5), (14), (18), (25), (27), cushion ring (19), seals (13,) (29), ball valve (17) and Needle Holder during assembly.

## Valve assembly

Replacement of the Valve Body onto the Cover assembly is the reverse of removal. Use a few turns of P.T.F.E. tape on the threads of the handle and screw on the Valve Body initially by hand, then insert the Valve Body in a vice, holding securely on the flats provided, and with the Cover (10) uppermost. Finally tighten up clockwise by hand, holding the Front Tube and Cover, and align the Throttle Lever with the front of the tool when resistance is felt. Replace the O'Ring (2) on the Valve Cap (1). Fit a new Valve seat O'Ring (5) in the Valve Body (6). Insert the Valve Stem (4), in the Valve Body (6). Place the Valve Spring (3) on top of the Valve Stem (4), screw down the Valve Cap (1) by hand, and then fasten until fully tight with a flat blade screwdriver.

Locate Throttle Lever (7) in the Valve Body (6) using a 3 mm punch to align holes.

Secure by inserting Spring Pin (8).

## Tool assembly

Ensure that all components are clean and lubricated with a thin film of the recommended lubricating oil. Assembly is the reverse of dismantling.

Secure the Cover (10) vertically in a vice using the flats provided, insert the Cylinder Guide Plate ensuring that the flat face is uppermost, ensure that it is located onto the shoulder at the bottom of the threaded section inside the Cover. Fit the Cylinder stem into the bore of the Cylinder Guide Plate. With the removal holes uppermost carefully slide the Intermediate Tube over the Cylinder, screwing down by hand. Finally tighten by using a 6mm bar x 200mm through the holes provided. **(Do not over tighten)**. Gently insert the Piston, small diameter first into the Intermediate Tube, if resistance is felt, turn the piston slightly until it is located in the cylinder.

**Note:** When removing tool from vice, do not point the front of the tool downward; the piston will fall out of the tube and become damaged. Remove the tool from the vice and follow as per [Re-fitting the Needles](#), hold the tool horizontal when completing this operation.

## Disposal

Dismantle into component form, segregate according to material composition and dispose of using waste recycling processes specified by local regulations.

# EXPLODED VIEW

## EXPLODED VIEW

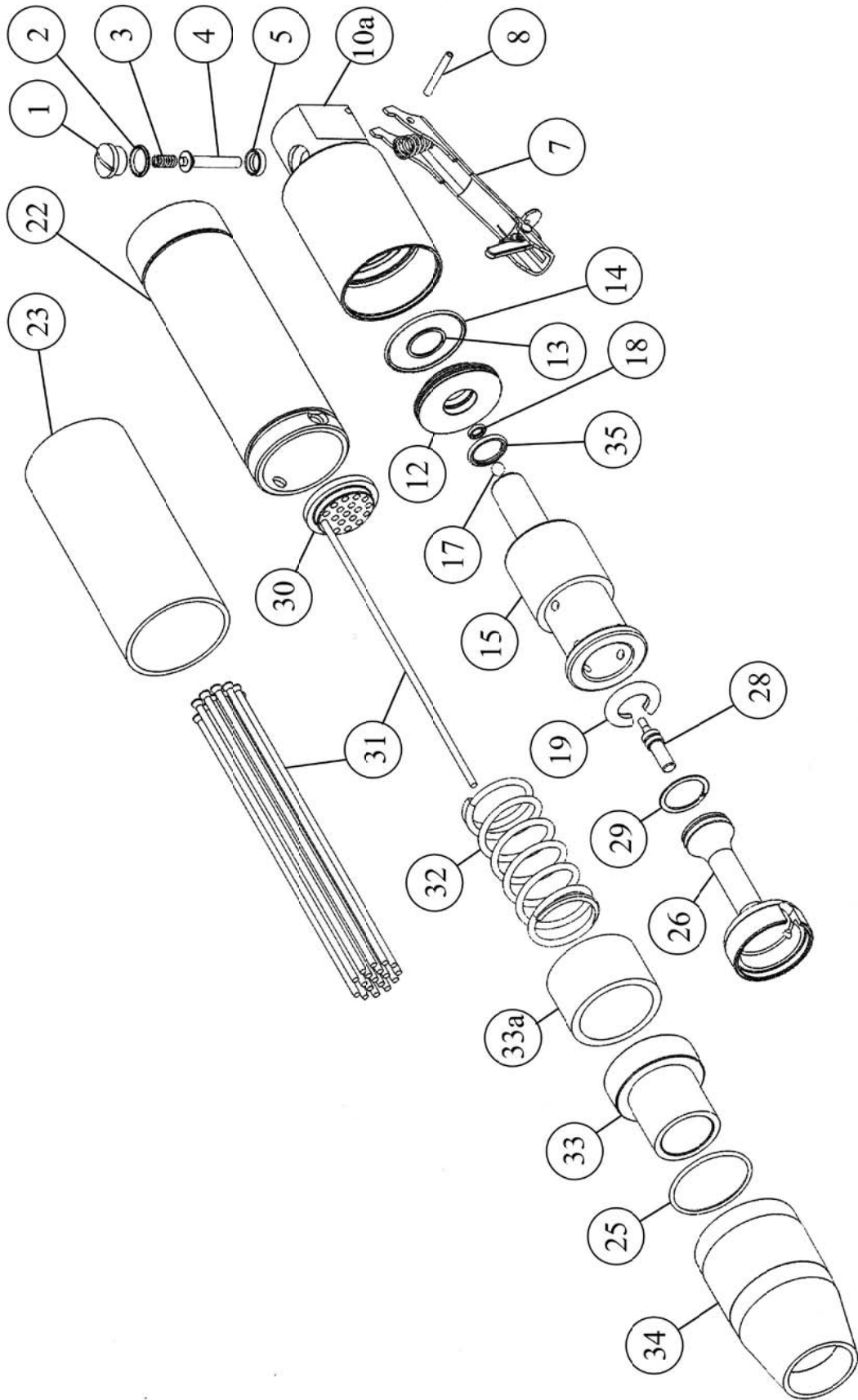

# PARTS LIST

ITEM No.	PART No.	DESCRIPTION	ITEM No.	PART No.	DESCRIPTION
<b>VL223 Components</b>			<b>VL223 Components</b>		
1	615.3021	Valve Cap			
2	809.0139	Valve Cap O'Ring			
3	712.3022	Valve Spring			
4	618.3022	Valve Stem	28	636.3003	Valve Pin
5	809.0089	Valve Seat O'Ring			
			36	610.2003	Anvil
			37	419.2003	Chisel Holder
7	716.1000	Safety Throttle Lever	38	704.3101	Chisel 1/2" Sq Shank 7" x 3/4" Blade
	716.3000	Throttle Lever		704.3103	Chisel 1/2" Sq Shank 7" x 2 1/2" Blade
8	813.0108	Roll Pin		704.3205	Chisel 1/2" Sq Shank 7" x 1 3/8" Blade
				704.3110	Chisel 1/2" Sq Shank Spark Resistant 2" Blade
10a	616.2003	VL223 Cover (Inline)		705.1102	Chisel 5/8" Hex Shank 8" x 4" Blade
	423.2023	VL223 Cover Assembly BSP Thread (inc 1-8 & 10a)		705.1106	Chisel 5/8" Hex Shank 9" x 2" Blade
	423.2203	VL223 Cover Assembly NPT Thread (inc 1-8 & 10a)		705.1112	Chisel 5/8" Hex Shank Spark Resistant 4" Blade
				708.1100	Comb Holder 5/8" Hex Shank (for 1 1/2" Comb)
12	652.2003	Guide Plate		431.3504	Scraper 5/8" Hex Shank c/w 4" Blade
13	829.2003	Guide Plate Seal			
14	809.0299	Guide Plate O'Ring			
15	428.2003	Cylinder			
17	816.3003	Plastic Ball 6mm diameter			
18	809.0080	Ball Retaining O'Ring			
19	809.2004	Piston Cushion		418.2003	Vacuum shroud assembly (with flat cuff)
22	622.2031	Intermediate Tube		731.2103	Flat Cuff
23	721.2003	Intermediate Tube Outer Sleeve		446.2003	Service Kit, (2, 5, 13, 14, 17, 18, 19, 28, 29, 30, 31 set & 32)
25	809.0299	Front Tube Locking O'Ring		819.2375	Connector 1/4" BSPT-3/8" Stem
26	612.2003	Piston			
29	829.2002	Piston Ring			
30	601.2030	3mm Needle Holder (fitted as standard)			
	601.2020	2mm Needle Holder			
31	413.2119	6 x Needle 3mm Chisel set (fitted as standard)			
	412.1151	6 x Needle 2mm Flat set			
	413.1119	6 x Needle 3mm Flat set			
	413.3119	6 x Needle 3mm Pointed set			
	403.1309	Needle set (1 x set Beryllium Copper)			
32	712.2003	Front Spring			
33	620.2003	Front Tube Insert			
33A	620.2003A	Front Tube Spacer			
34	622.2030	Front Tube			
35	809.3005	Cylinder Stem Reaction Ring			

# TECHNICAL SPECIFICATION

TROUBLE SHOOTING	CAUSE	ACTION
Poor performance or lack of power.	Low air pressure.	Ensure that the air pressure is correct at 90psi, max 100psi.
	If tool has been left for some time without use, the oil may dry out slightly, causing a sticky residue.	Strip tool down, clean and re-oil.
	Needles worn or some missing.	Replace with new set of needles and new needle holder.
	Piston seal worn.	Remove seal from piston and fit into bore of cylinder. If it drops to the bottom of the bore, a replacement is required.
	Incorrect chisel fitted.	Ensure that the chisel is for a vibration reduced tool.
Tool continues to run with trigger released.	Valve pin broken.	Replace valve pin and 6mm plastic ball.
	Valve seal may have become dislodged through the tool being disconnected with the trigger in the open position.	Ensure that the trigger has not been taped or wired in the open position, reposition or replace valve seat o'ring.
High vibration.	High air pressure.	Ensure that the air pressure is correct at 90psi, max 100psi.
	Lack of lubrication.	Lubricate with the recommended air tool oil daily.
	Low air pressure 70-80psi can also cause high vibration.	Ensure that the air pressure is correct at 90psi, max 100psi.
	Front return spring weak or broken.	Replace return spring.
	Guide plate seal worn.	Replace guide plate seal.
	Piston cushion failed. (This is a split o'ring)	Replace with a new piston cushion.
Tool stopped working.	6mm plastic ball worn out.	Check for and remove the remains of the ball, possibly in an exhaust hole of cylinder and renew 6mm plastic ball.
	Valve pin broken.	Replace valve pin and 6mm plastic ball.

	VL223 INLINE NEEDLE	VL223 INLINE CHISEL
Piston Diameter	23.5mm (0.925")	23.5mm (0.925")
Piston Stroke (approximate)	11mm (0.43")	11mm (0.43")
BPM	2400	2400
Air Consumption @ 6.2bar	1.89lps (4.0cfm)	1.89lps (4.0cfm)
Overall Length	370mm (14.5")	435mm (17.1")
Weight	2.35kg (5.18lbs)	2.95kg (6.5lbs)
Needle/Chisel	51 x 2mm 19 x 3mm	19mm (3/4") Standard fit
Noise LwA (Power Level)	90.7 db(A)	76.3 db(A)
Vibration (AEQ) Primary	2.56 m/s <sup>2</sup> (k)	3.69 m/s <sup>2</sup> (k)
Vibration (AEQ) Secondary	2.95 m/s <sup>2</sup> (k)	3.59 m/s <sup>2</sup> (k)

**Noise Levels** Noise level measured in accordance with: EN ISO 15744: 1999  
**Vibration Levels** Vibration measured in accordance with: EN ISO 28927 and EN ISO 20643. (k) Equals the factor of uncertainty, which allows for variations in measurement and production. Vibration Data figures are tri-axial, which gives the total vibration emission. Because of various factors, the range of vibration from these tools may vary between -0% +40%. The vibration is dependent on the task, the operators grip and feed force employed etc.  
**NOTE:** The above vibration levels were obtained from tri-axial measurements to comply with the requirements of "The Control of Vibration at Work Regulations 2005" and the revisions to the (8662) now EN ISO 28927 and EN ISO 20643 series of standards. These values are at least 1.4 times larger than the values obtained from single axis measurements.  
 \*Based on European Union Council Directive 2002/44/EC (Physical Agents (Vibration) Directive).  
**Risk of Hand Arm Injury**  
 Because of various factors, the vibration from this range of tools may be between 2.95 m/s<sup>2</sup> – 4.13m/s<sup>2</sup>  
 The vibration is dependent on the task, the operators grip, and feed force employed.

#### Machinery Directive Information:

This tool has been designed and produced in accordance with the following directives: 2006/42/EC Machinery Directive and applicable harmonised standard: EN ISO 1 1148-4:2010

If your company has any problem with our products or would like to discuss the possibility of an improvement being made to them, then please do not hesitate to contact us. Your comments are both important and appreciated.

Trelawny tools are thoroughly tested under specified conditions in accordance with applicable internationally recognised standards. When a tool is used on site the conditions may not be the same as those used in our tests.

Trelawny Surface Preparation Technology operates a policy of continuous product development and refinement and therefore reserves the right to change technical specifications and product designs without giving prior notice.

© Copyright 2009, Trelawny SPT Limited, CV31 1XT. UK All rights reserved. Any unauthorised use or copying of the contents or part thereof is prohibited. This applies to trademarks, model denominations, part numbers and drawings. Use only genuine Trelawny spares.

**The use of non-Trelawny spare parts invalidates the warranty.**



# TRELAWNY

SURFACE PREPARATION TECHNOLOGY

Distributed exclusively by:



22 Harbor Avenue, Norwalk, CT 06850 USA

Toll-Free: 800-700-5919

Phone: 203-853-9522

Fax: 203-853-9921

Email: info@csunitec.com

[www.csunitec.com](http://www.csunitec.com)

